



**MINMAX<sup>®</sup>**

MSCWI03 Series

Electric Characteristic Note

# MSCWI03 Series EC Note

DC-DC CONVERTER 3W, SMD Package

## Features

- ▶ Very Compact SMD Package
- ▶ Ultra-wide 4:1 Input Voltage Range
- ▶ Fully Regulated Output Voltage
- ▶ I/O Isolation 1500VDC
- ▶ Operating Ambient Temp. Range -40°C to +80°C
- ▶ No Min. Load Requirement
- ▶ Under-voltage, Overload and Short Circuit Protection
- ▶ Remote On/Off Control
- ▶ EMI Emission EN 55032 Class A Approved
- ▶ Cleaning-washable Process Available(option)
- ▶ Qualified for Lead-free Reflow Solder Process According to IPC/JEDEC J-STD-020D.1
- ▶ Tape & Reel Package Available
- ▶ UL/cUL/IEC/EN 62368-1(60950-1) Safety Approval & CE Marking



## Applications

- ▶ Distributed power architectures
- ▶ Workstations
- ▶ Computer equipment
- ▶ Communications equipment

## Product Overview

The MINMAX MSCWI03 series is a range of isolated 3W DC-DC converter modules features ultra-wide input voltage ranges and fully regulated output voltage. The product come in a SMD package with very small footprint occupying only 0.3 in<sup>2</sup> (0.2 cm<sup>2</sup>) of PCB space. The converters are qualified to withstand lead free reflow processes according to IPC J-STD-020D.1 standard. High efficiency allows operating temperatures range of -40°C to 80°C. Further features include under-voltage protection, overload protection, short circuit protection, no min. load requirement and remote ON/OFF. These DC-DC converters offer the best solution for many space critical applications in battery-powered equipment, instrumentation, distributed power architectures in communication and industrial electronics.

## Table of contents

Model Selection Guide .....	P2	Test Setup.....	P23
Input Specifications.....	P2	Technical Notes .....	P23
Remote On/Off Specifications .....	P2	Remote On/Off Implementation.....	P24
Output Specifications.....	P3	Packaging Information for Tube .....	P24
General Specifications.....	P3	Packaging Information for Tape & Reel.....	P25
EMC Specifications.....	P3	Soldering and Reflow Considerations .....	P26
Environmental Specifications .....	P3	Part Number Structure .....	P27
Characteristic Curves .....	P4	MTBF and Reliability .....	P27
Package Specifications .....	P22		

**Model Selection Guide**

Model Number	Input Voltage (Range)	Output Voltage	Output Current	Input Current		Max. capacitive Load	Efficiency (typ.)
				@Max. Load	@No Load		
	VDC	VDC	mA	mA(typ.)	mA(typ.)	μF	%
MSCWI03-05S05	5 (4.5 ~ 12)	5	600	741	40	1680	81
MSCWI03-05S12		12	250	714		820	84
MSCWI03-05S15		15	200	714		680	84
MSCWI03-05S24		24	125	714		390	84
MSCWI03-05D12		±12	±125	723		470#	83
MSCWI03-05D15		±15	±100	723		330#	83
MSCWI03-24S05	24 (9 ~ 36)	5	600	156	20	1680	80
MSCWI03-24S12		12	250	147		820	85
MSCWI03-24S15		15	200	147		680	85
MSCWI03-24S24		24	125	147		390	85
MSCWI03-24D12		±12	±125	149		470#	84
MSCWI03-24D15		±15	±100	149		330#	84
MSCWI03-48S05	48 (18 ~ 75)	5	600	78	13	1680	80
MSCWI03-48S12		12	250	74		820	84
MSCWI03-48S15		15	200	74		680	84
MSCWI03-48S24		24	125	74		390	85
MSCWI03-48D12		±12	±125	75		470#	83
MSCWI03-48D15		±15	±100	76		330#	82

# For each output

**Input Specifications**

Parameter	Conditions / Model	Min.	Typ.	Max.	Unit
Input Surge Voltage (1 sec. max.)	5V Input Models	-0.7	---	15	VDC
	24V Input Models	-0.7	---	50	
	48V Input Models	-0.7	---	100	
Start-Up Threshold Voltage	5V Input Models	---	---	4.5	VDC
	24V Input Models	---	---	9	
	48V Input Models	---	---	18	
Start-Up Time (Power On)	Nominal Vin and Constant Resistive Load	---	---	30	ms
Short Circuit Input Power	All Models	---	---	1500	mW
Input Filter		Internal Pi Type			

**Remote On/Off Specifications**

Parameter	Conditions	Min.	Typ.	Max.	Unit
Converter On	Under 0.6 VDC or Open Circuit				
Converter Off	4.7 to 15 VDC				
Standby Input Current	Nominal Vin	---	---	3	mA

Output Specifications					
Parameter	Conditions	Min.	Typ.	Max.	Unit
Output Voltage Setting Accuracy		---	---	±1.0	%Vnom.
Output Voltage Balance	Dual Output, Balanced Loads	---	---	±2.0	%
Line Regulation	Vin=Min. to Max. @Full Load	---	---	±0.5	%
Load Regulation	Io=0% to 100%	---	---	±1.0	%
Load Cross Regulation (Dual Output)	Asymmetrical Load 25/100% Full Load	---	---	±5.0	%
Minimum Load	No minimum Load Requirement				
Ripple & Noise	0-20 MHz Bandwidth	---	---	50	mV <sub>P-P</sub>
Transient Recovery Time	25% Load Step Change	---	250	---	μsec
Transient Response Deviation		---	±3	±5	%
Temperature Coefficient		---	---	±0.02	%/°C
Over Load Protection	Foldback	---	160	---	%
Short Circuit Protection	Continuous, Automatic Recovery				

General Specifications					
Parameter	Conditions	Min.	Typ.	Max.	Unit
I/O Isolation Voltage	60 Seconds	1500	---	---	VDC
	1 Second	1800	---	---	VDC
I/O Isolation Resistance	500 VDC	1000	---	---	MΩ
I/O Isolation Capacitance	100kHz, 1V	---	500	---	pF
Switching Frequency		100	---	---	kHz
MTBF(calculated)	MIL-HDBK-217F@25°C, Ground Benign	5,086,000	---	---	Hours
Moisture Sensitivity Level (MSL)	IPC/JEDEC J-STD-020D.1	Level 2			
Safety Approvals	UL/cUL 60950-1 recognition(UL certificate), IEC/EN 60950-1(CB-report)				
	UL/cUL 62368-1 recognition(UL certificate), IEC/EN 62368-1(CB-report)				

EMC Specifications			
Parameter	Standards & Level		Performance
EMI	Conduction	EN 55032	Without external components
	Radiation		
EMS <sub>(4)</sub>	EN 55035		
	ESD	EN 61000-4-2 Air ± 8kV, Contact ± 6kV	
	Radiated immunity	EN 61000-4-3 10V/m	
	Fast transient	EN 61000-4-4 ±2kV	
	Surge	EN 61000-4-5 ±1kV	
	Conducted immunity	EN 61000-4-6 10Vrms	
	PFMF	EN 61000-4-8 3A/m	

Environmental Specifications			
Parameter	Min.	Max.	Unit
Operating Ambient Temperature Range (See Power Derating Curve)	-40	+80	°C
Case Temperature	---	+95	°C
Storage Temperature	-55	+125	°C
Humidity (non condensing)	---	95	% rel. H
Lead-free reflow solder process	IPC/JEDEC J-STD-020D.1		

Notes
1 Specifications typical at Ta=+25°C, resistive load, nominal input voltage, rated output current unless otherwise noted.
2 We recommend to protect the converter by a slow blow fuse in the input supply line.
3 Other input and output voltage may be available, please contact MINMAX.
4 The external components might be required to meet EMS standard for some of test items. Please contact MINMAX for the solution in detail.
5 Specifications are subject to change without notice.

**Characteristic Curves**

All test conditions are at 25°C The figures are identical for MSCWI03-05S05

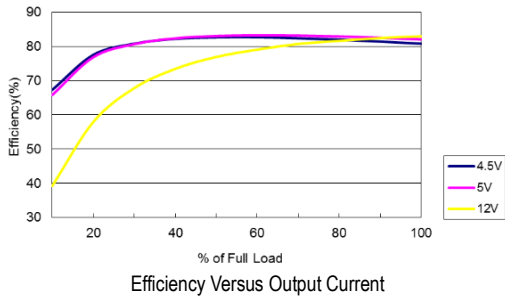

Efficiency Versus Output Current

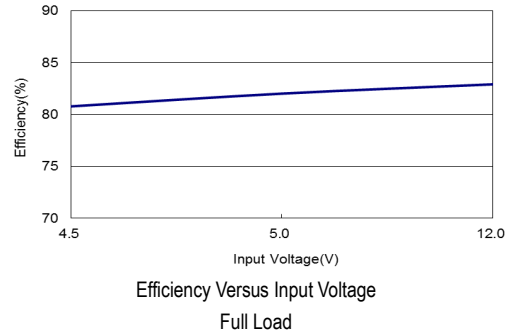

Efficiency Versus Input Voltage Full Load

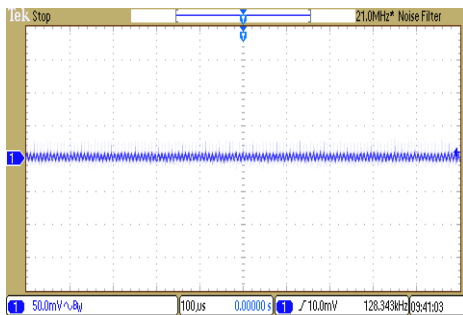

Typical Output Ripple and Noise  
 $V_{in}=V_{in\ nom}$ ; Full Load

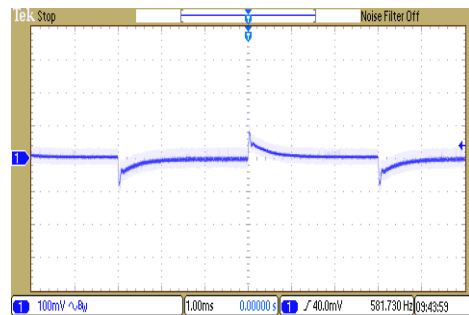

Transient Response to Dynamic Load Change  
from 100% to 75% of Full Load ;  $V_{in}=V_{in\ nom}$

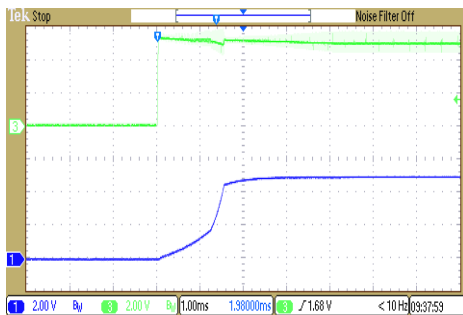

Typical Input Start-Up and Output Rise Characteristic  
 $V_{in}=V_{in\ nom}$ ; Full Load

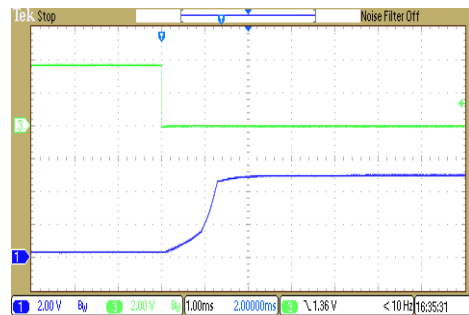

ON/OFF Voltage Start-Up and Output Rise Characteristic  
 $V_{in}=V_{in\ nom}$ ; Full Load

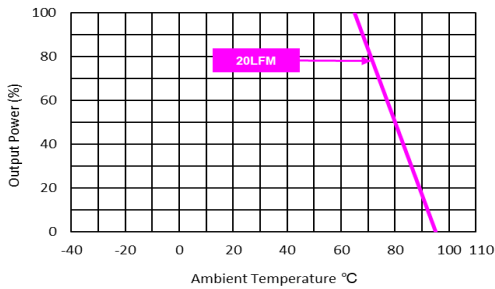

Derating Output Current Versus Ambient Temperature and Airflow  
 $V_{in}=V_{in\ nom}$

**Characteristic Curves**

All test conditions are at 25°C The figures are identical for MSCWI03-05S12

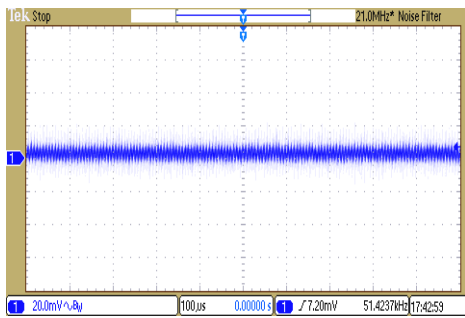
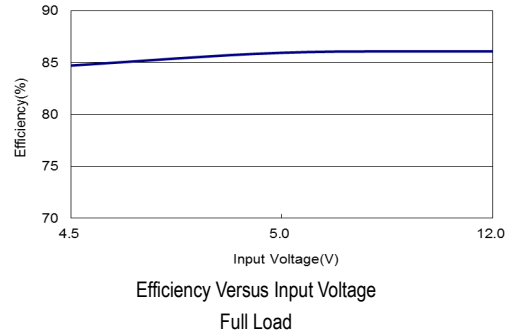
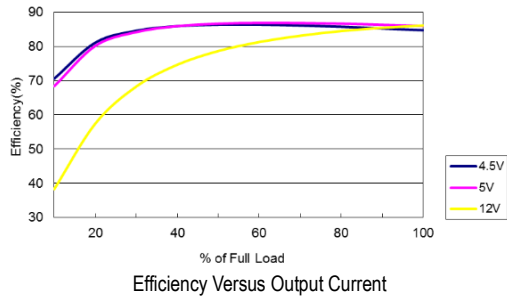

Typical Output Ripple and Noise  
 $V_{in}=V_{in\ nom}$ ; Full Load

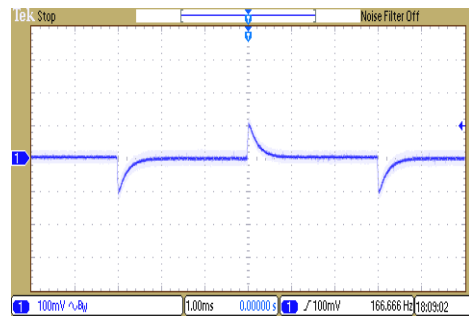

Transient Response to Dynamic Load Change  
from 100% to 75% of Full Load;  $V_{in}=V_{in\ nom}$

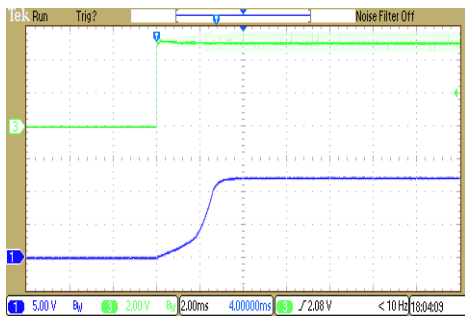

Typical Input Start-Up and Output Rise Characteristic  
 $V_{in}=V_{in\ nom}$ ; Full Load

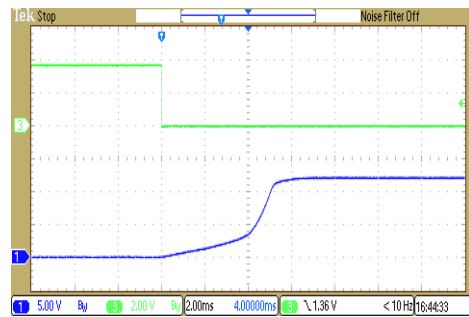

ON/OFF Voltage Start-Up and Output Rise Characteristic  
 $V_{in}=V_{in\ nom}$ ; Full Load

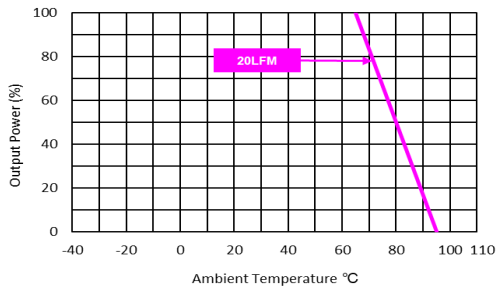

Derating Output Current Versus Ambient Temperature and Airflow  
 $V_{in}=V_{in\ nom}$

**Characteristic Curves**

All test conditions are at 25°C The figures are identical for MSCWI03-05S15

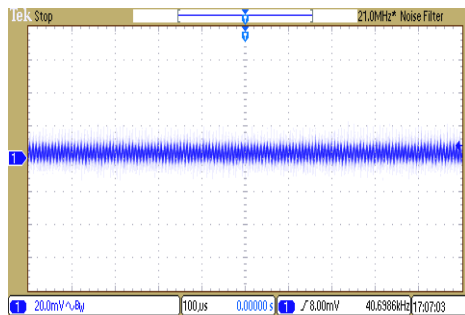
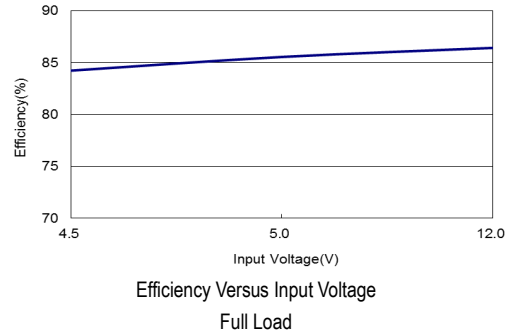
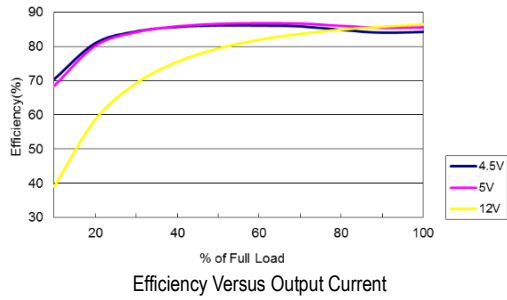

Typical Output Ripple and Noise  
 $V_{in}=V_{in\ nom}$ ; Full Load

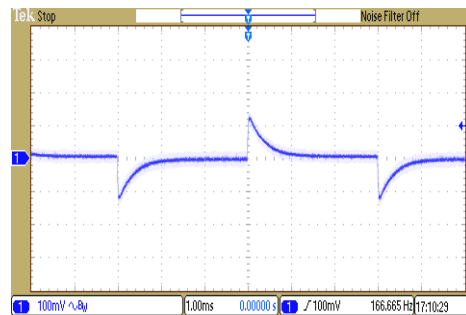

Transient Response to Dynamic Load Change  
from 100% to 75% of Full Load;  $V_{in}=V_{in\ nom}$

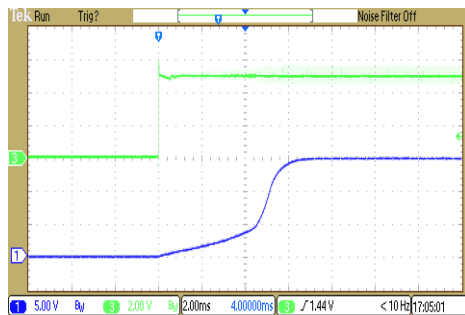

Typical Input Start-Up and Output Rise Characteristic  
 $V_{in}=V_{in\ nom}$ ; Full Load

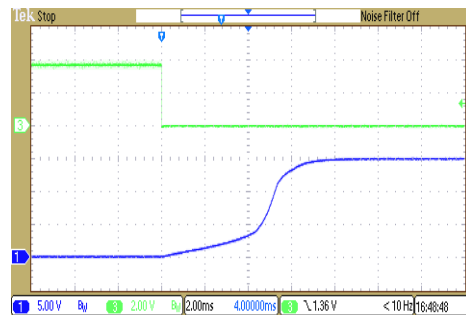

ON/OFF Voltage Start-Up and Output Rise Characteristic  
 $V_{in}=V_{in\ nom}$ ; Full Load

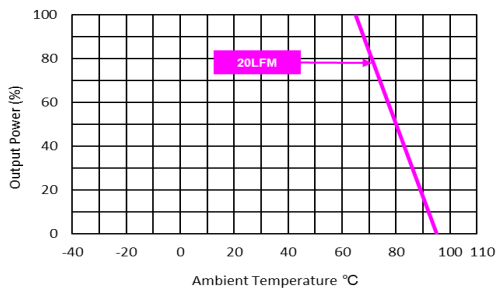

Derating Output Current Versus Ambient Temperature and Airflow  
 $V_{in}=V_{in\ nom}$



**Characteristic Curves**

All test conditions are at 25°C The figures are identical for MSCWI03-05S24

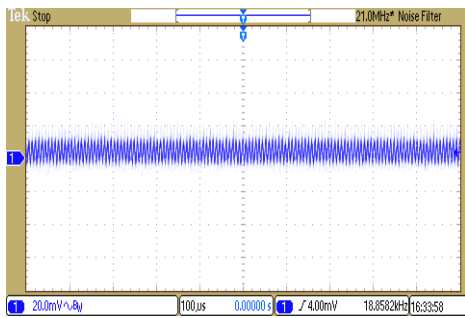
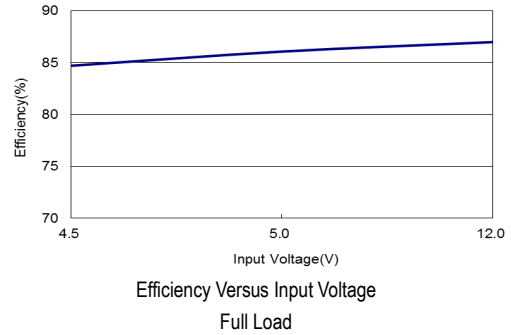
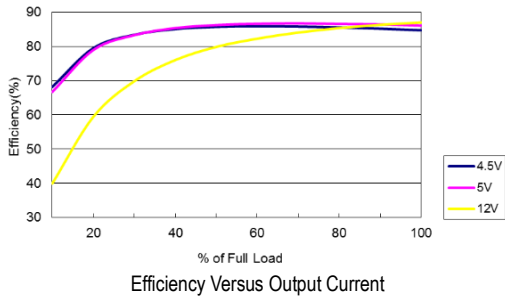

Typical Output Ripple and Noise  
 $V_{in}=V_{in\ nom}$ ; Full Load

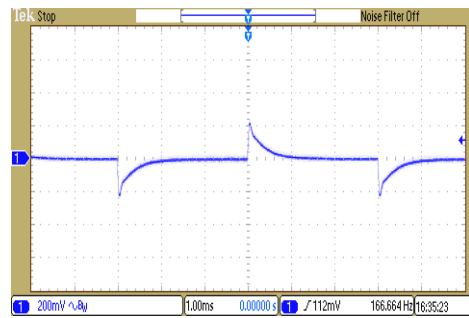

Transient Response to Dynamic Load Change  
from 100% to 75% of Full Load;  $V_{in}=V_{in\ nom}$

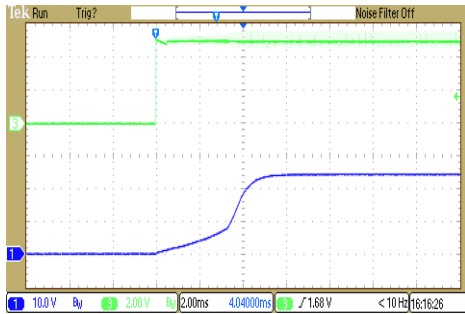

Typical Input Start-Up and Output Rise Characteristic  
 $V_{in}=V_{in\ nom}$ ; Full Load

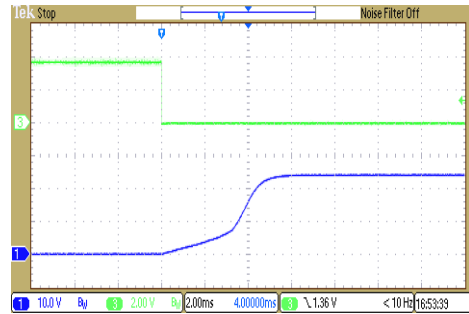

ON/OFF Voltage Start-Up and Output Rise Characteristic  
 $V_{in}=V_{in\ nom}$ ; Full Load

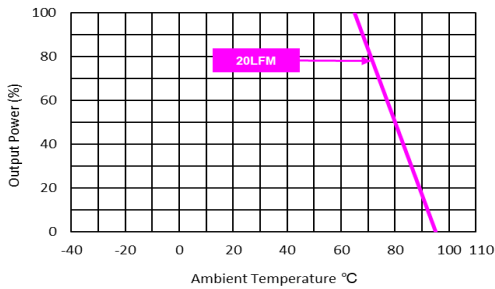

Derating Output Current Versus Ambient Temperature and Airflow  
 $V_{in}=V_{in\ nom}$



**Characteristic Curves**

All test conditions are at 25°C. The figures are identical for MSCWI03-05D12

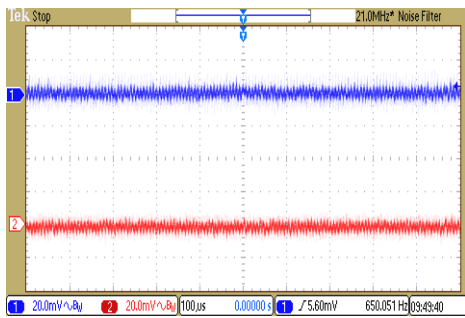
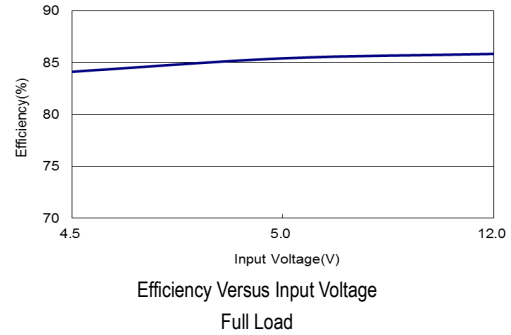
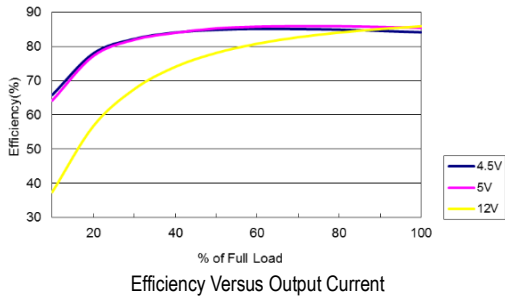

Typical Output Ripple and Noise  
 $V_{in}=V_{in\ nom}$ ; Full Load

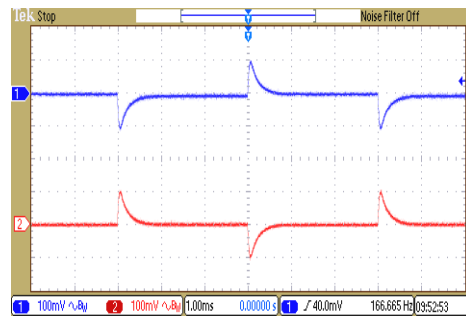

Transient Response to Dynamic Load Change  
from 100% to 75% of Full Load;  $V_{in}=V_{in\ nom}$

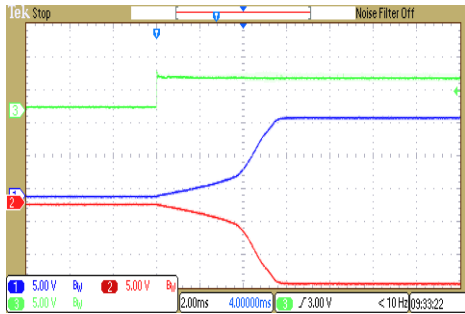

Typical Input Start-Up and Output Rise Characteristic  
 $V_{in}=V_{in\ nom}$ ; Full Load

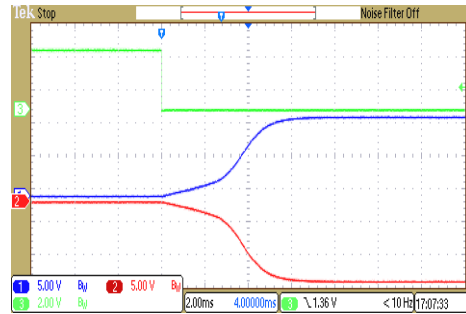

ON/OFF Voltage Start-Up and Output Rise Characteristic  
 $V_{in}=V_{in\ nom}$ ; Full Load

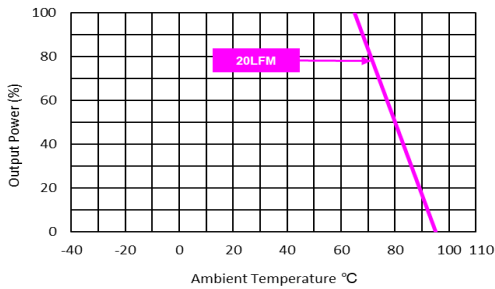

Derating Output Current Versus Ambient Temperature and Airflow  
 $V_{in}=V_{in\ nom}$

**Characteristic Curves**

All test conditions are at 25°C The figures are identical for MSCWI03-05D15

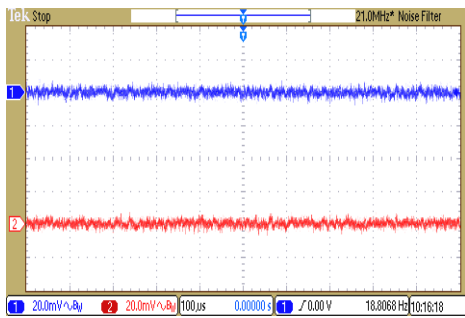
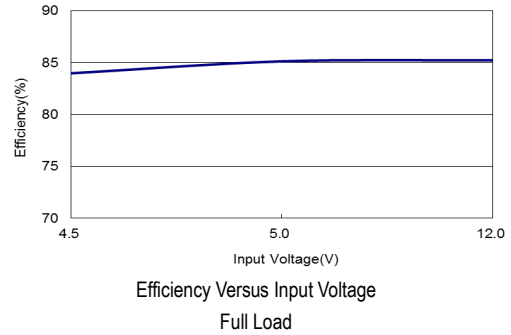
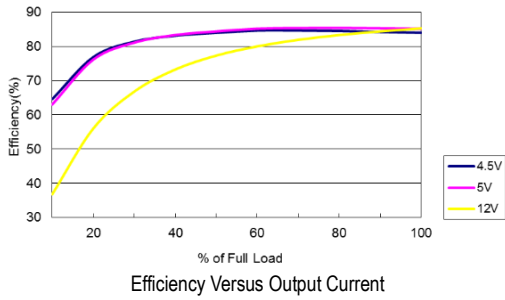

Typical Output Ripple and Noise  
 $V_{in}=V_{in\ nom}$ ; Full Load

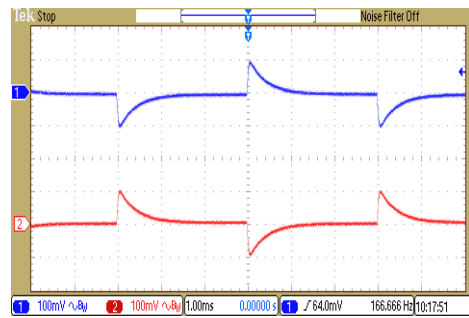

Transient Response to Dynamic Load Change  
from 100% to 75% of Full Load ;  $V_{in}=V_{in\ nom}$

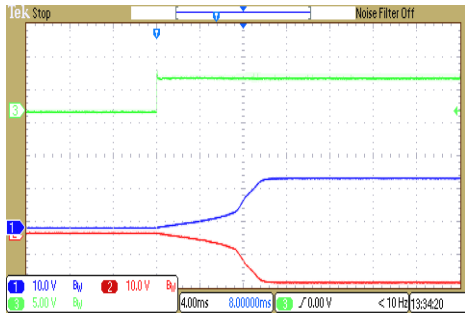

Typical Input Start-Up and Output Rise Characteristic  
 $V_{in}=V_{in\ nom}$ ; Full Load

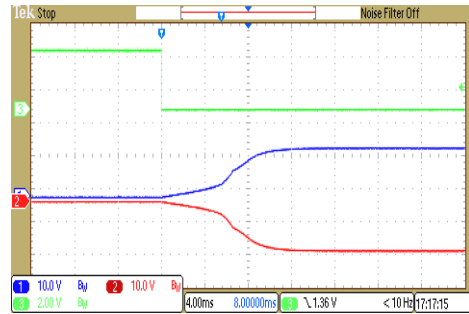

ON/OFF Voltage Start-Up and Output Rise Characteristic  
 $V_{in}=V_{in\ nom}$ ; Full Load

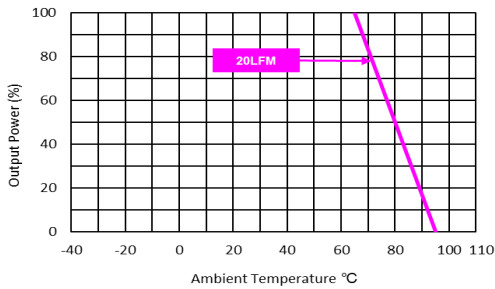

Derating Output Current Versus Ambient Temperature and Airflow  
 $V_{in}=V_{in\ nom}$

**Characteristic Curves**

All test conditions are at 25°C The figures are identical for MSCWI03-24S05

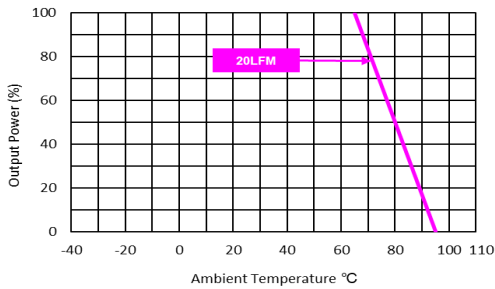
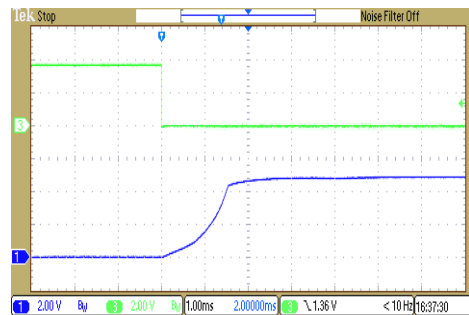
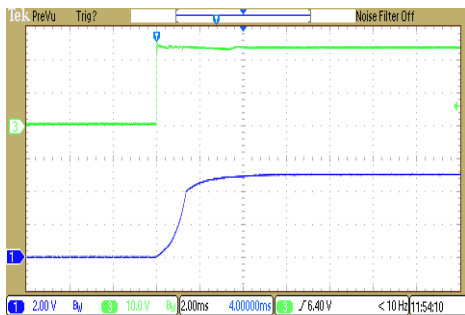
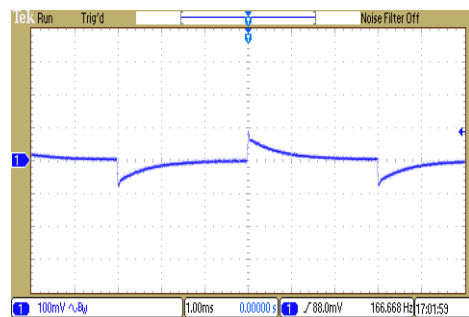
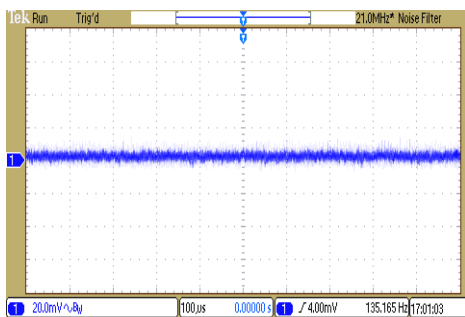
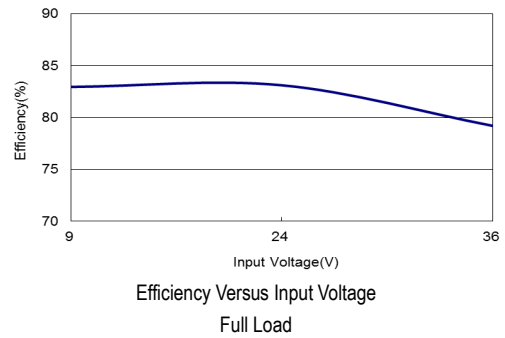
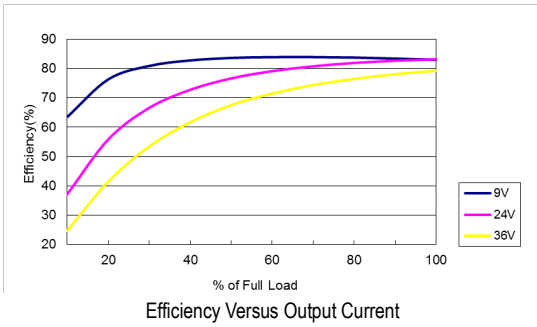

**Characteristic Curves**

All test conditions are at 25°C The figures are identical for MSCWI03-24S12

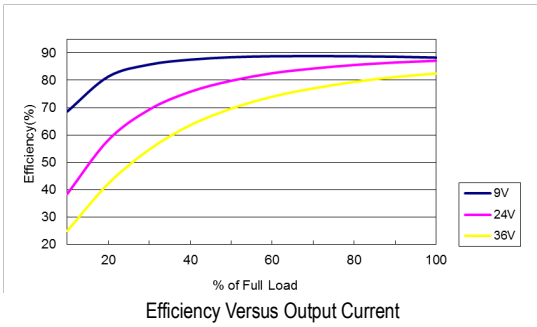

Efficiency Versus Output Current

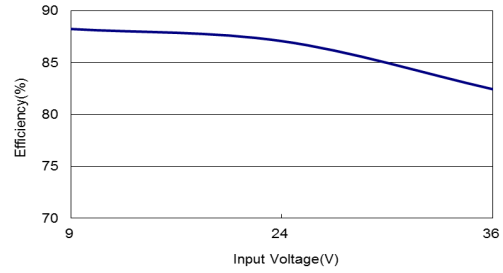

Efficiency Versus Input Voltage Full Load

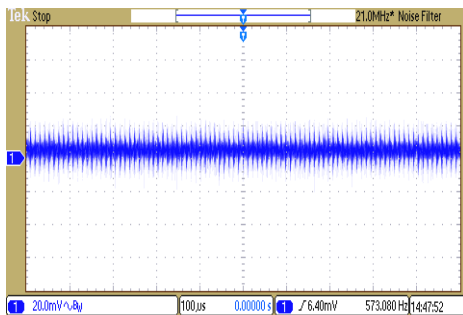

Typical Output Ripple and Noise  
 $V_{in}=V_{in\ nom}$ ; Full Load

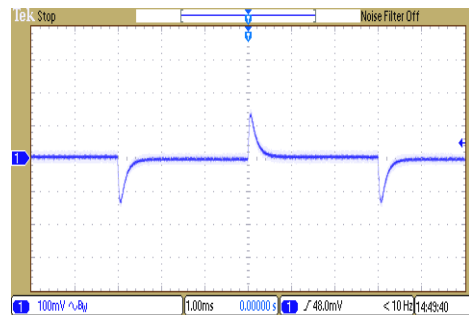

Transient Response to Dynamic Load Change  
from 100% to 75% of Full Load ;  $V_{in}=V_{in\ nom}$

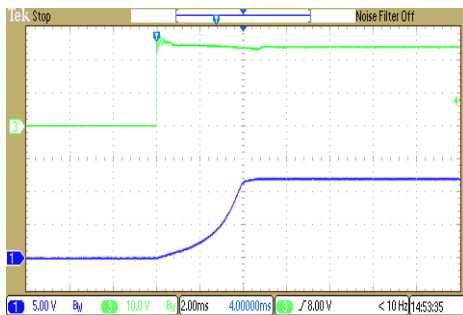

Typical Input Start-Up and Output Rise Characteristic  
 $V_{in}=V_{in\ nom}$ ; Full Load

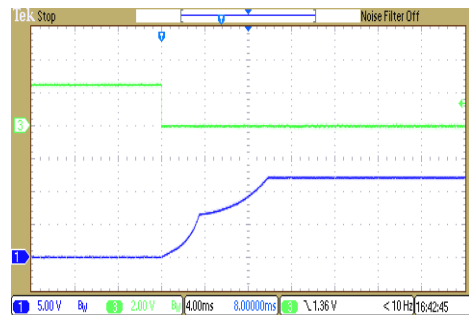

ON/OFF Voltage Start-Up and Output Rise Characteristic  
 $V_{in}=V_{in\ nom}$ ; Full Load

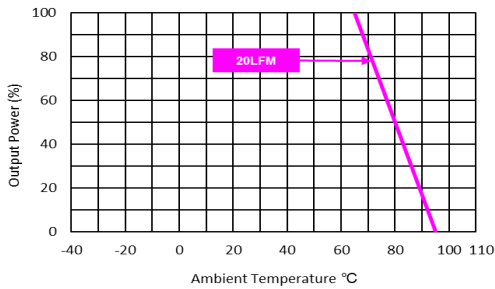

Derating Output Current Versus Ambient Temperature and Airflow  
 $V_{in}=V_{in\ nom}$

**Characteristic Curves**

All test conditions are at 25°C The figures are identical for MSCWI03-24S15

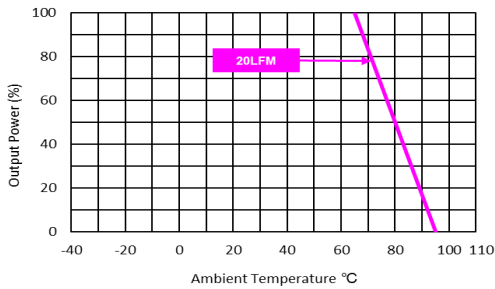
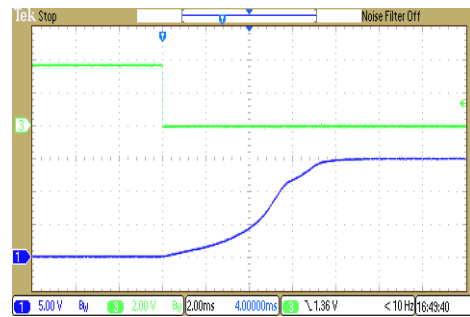
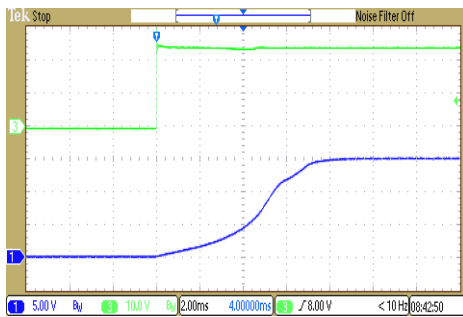
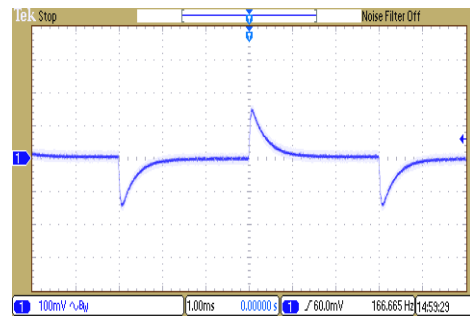
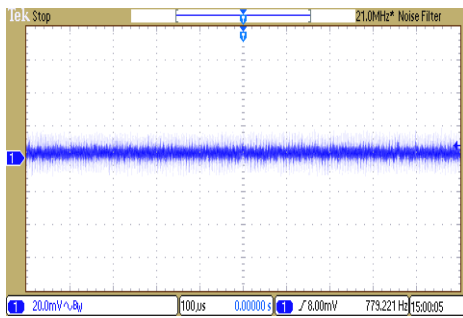
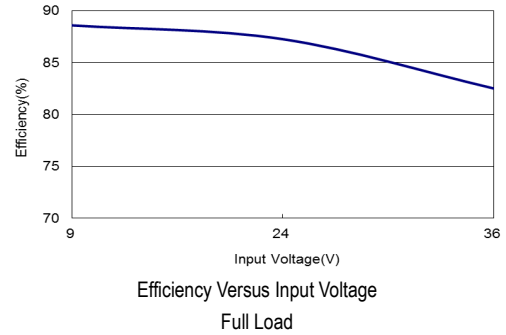
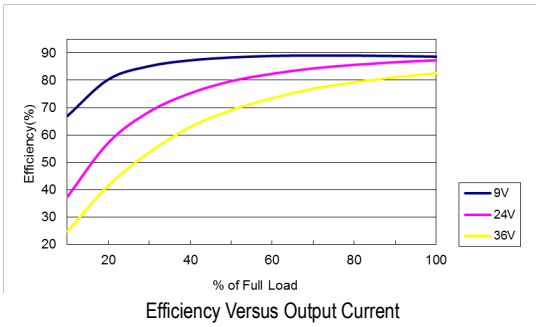

**Characteristic Curves**

All test conditions are at 25°C The figures are identical for MSCWI03-24S24

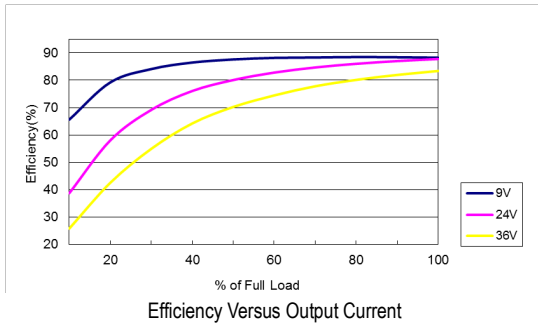

Efficiency Versus Output Current

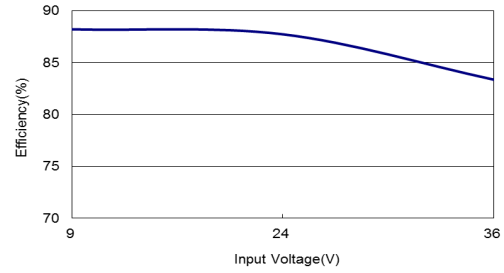

Efficiency Versus Input Voltage Full Load

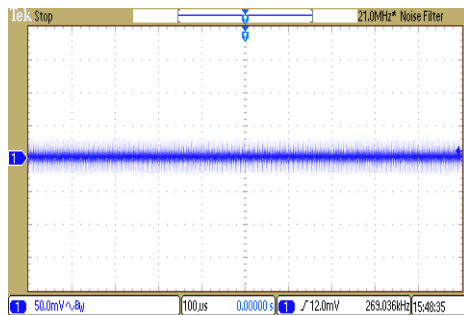

Typical Output Ripple and Noise  
 $V_{in}=V_{in\ nom}$ ; Full Load

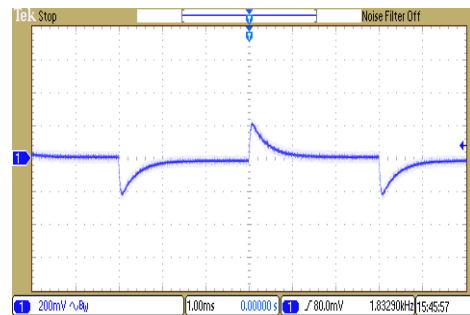

Transient Response to Dynamic Load Change  
from 100% to 75% of Full Load ;  $V_{in}=V_{in\ nom}$

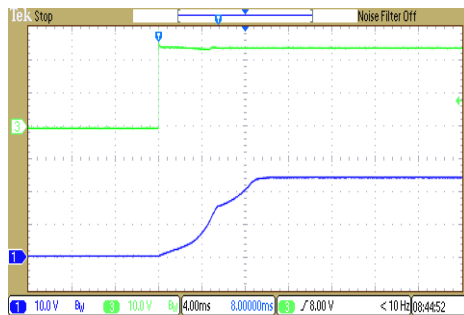

Typical Input Start-Up and Output Rise Characteristic  
 $V_{in}=V_{in\ nom}$ ; Full Load

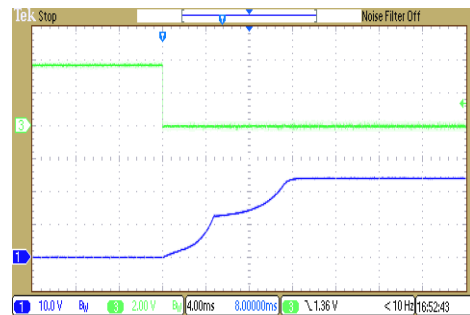

ON/OFF Voltage Start-Up and Output Rise Characteristic  
 $V_{in}=V_{in\ nom}$ ; Full Load

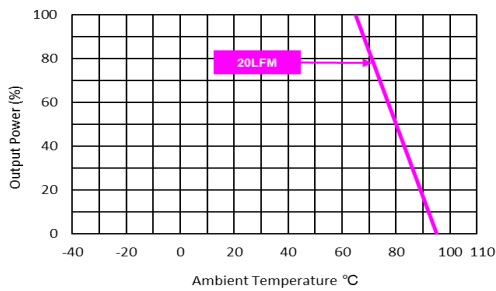

Derating Output Current Versus Ambient Temperature and Airflow  
 $V_{in}=V_{in\ nom}$



**Characteristic Curves**

All test conditions are at 25°C The figures are identical for MSCWI03-24D12

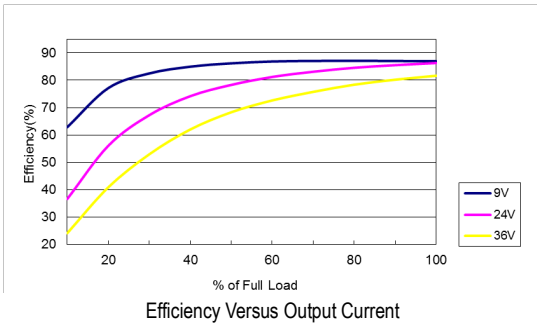

Efficiency Versus Output Current

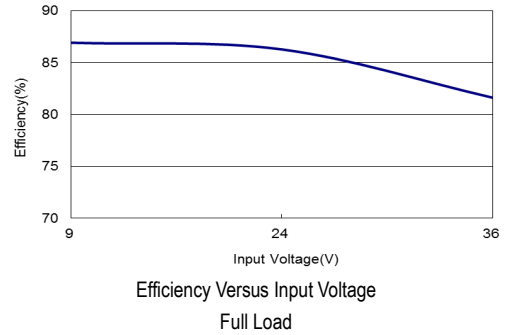

Efficiency Versus Input Voltage Full Load

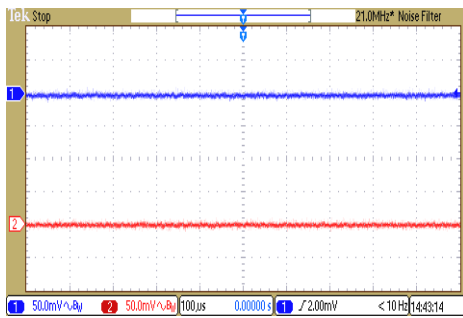

Typical Output Ripple and Noise  
 $V_{in}=V_{in\ nom}$ ; Full Load

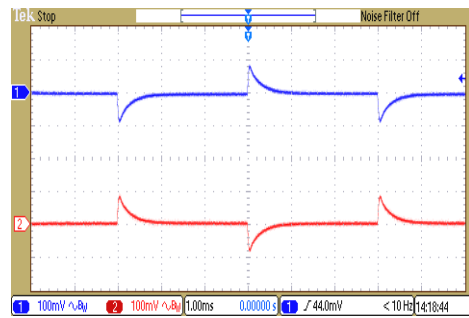

Transient Response to Dynamic Load Change  
from 100% to 75% of Full Load ;  $V_{in}=V_{in\ nom}$

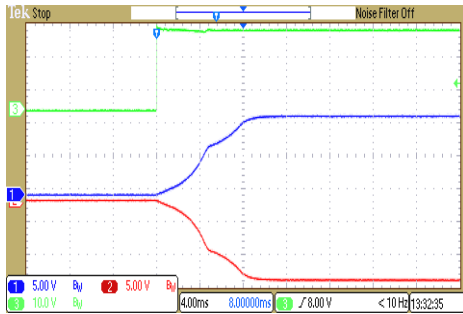

Typical Input Start-Up and Output Rise Characteristic  
 $V_{in}=V_{in\ nom}$ ; Full Load

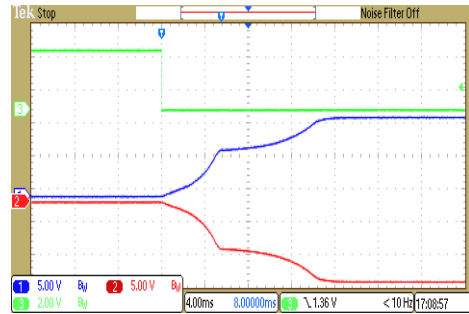

ON/OFF Voltage Start-Up and Output Rise Characteristic  
 $V_{in}=V_{in\ nom}$ ; Full Load

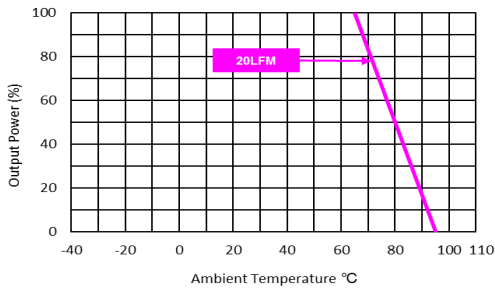

Derating Output Current Versus Ambient Temperature and Airflow  
 $V_{in}=V_{in\ nom}$



**Characteristic Curves**

All test conditions are at 25°C The figures are identical for MSCWI03-24D15

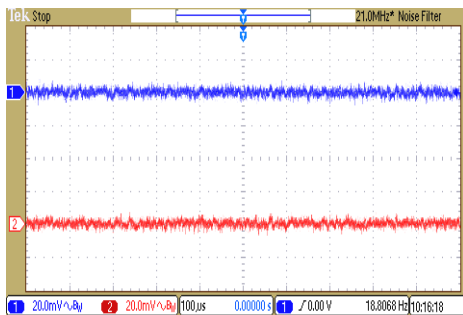
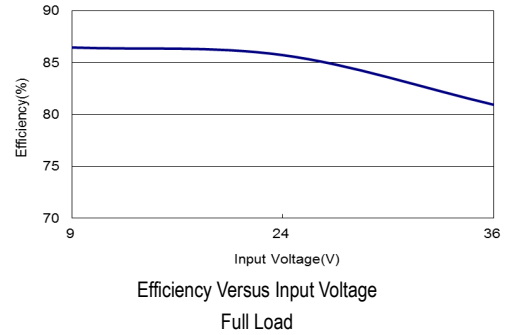
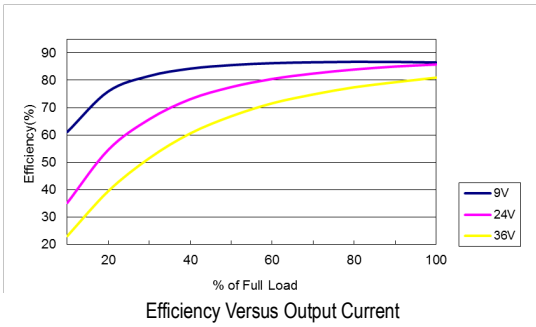

Typical Output Ripple and Noise  
 $V_{in}=V_{in\ nom}$ ; Full Load

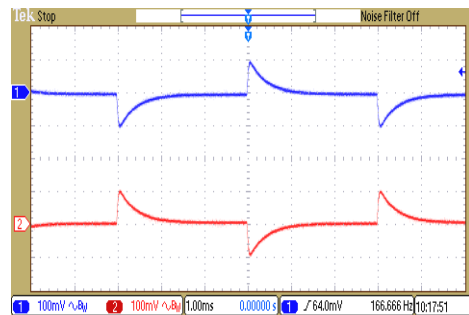

Transient Response to Dynamic Load Change  
from 100% to 75% of Full Load ;  $V_{in}=V_{in\ nom}$

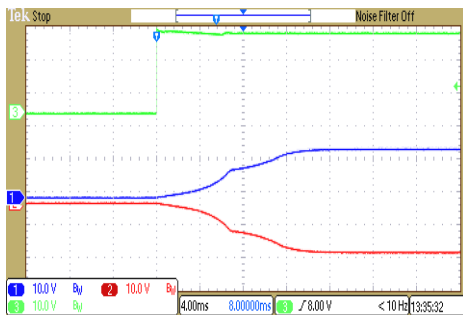

Typical Input Start-Up and Output Rise Characteristic  
 $V_{in}=V_{in\ nom}$ ; Full Load

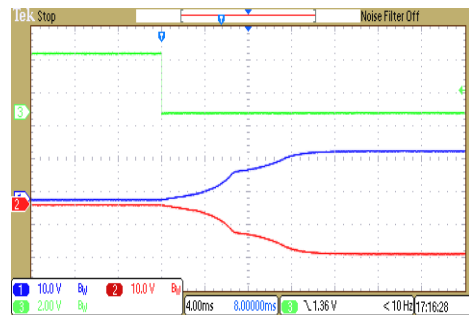

ON/OFF Voltage Start-Up and Output Rise Characteristic  
 $V_{in}=V_{in\ nom}$ ; Full Load

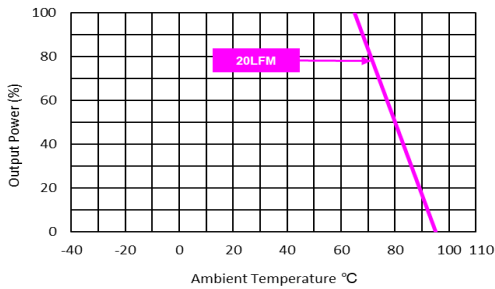

Derating Output Current Versus Ambient Temperature and Airflow  
 $V_{in}=V_{in\ nom}$

**Characteristic Curves**

All test conditions are at 25°C The figures are identical for MSCWI03-48S05

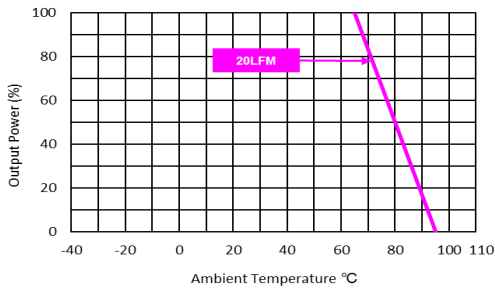
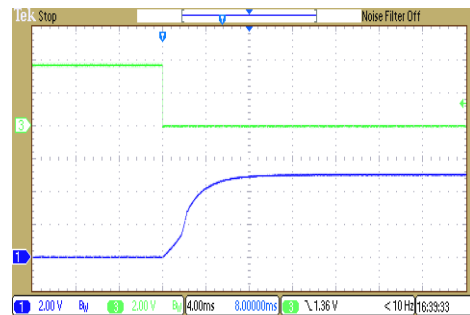
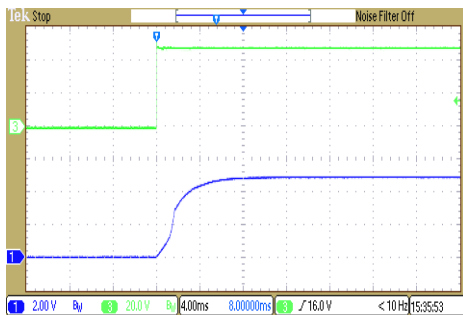
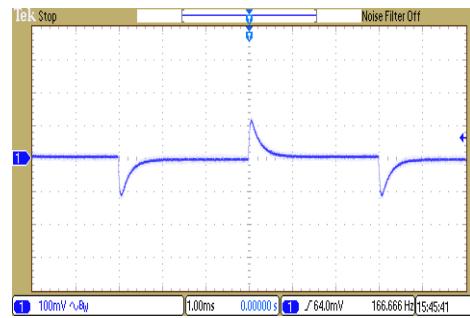
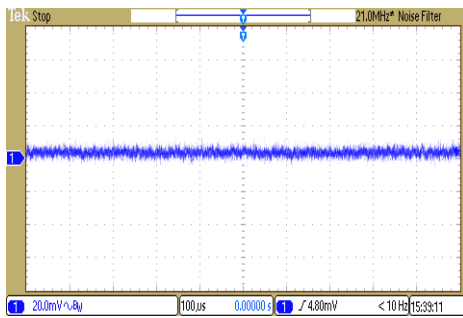
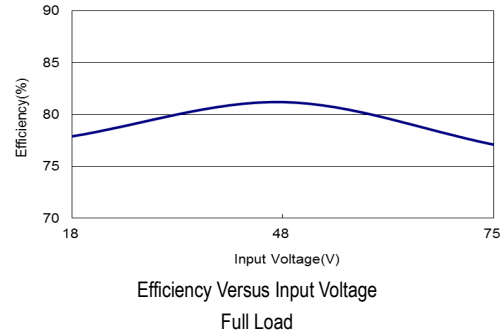
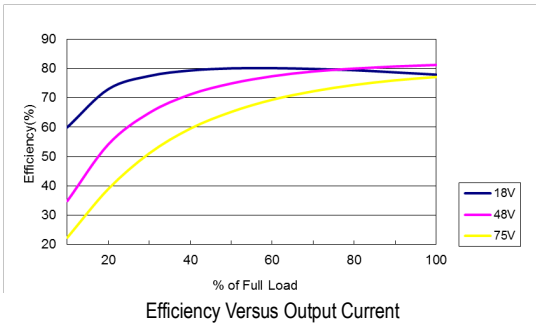

**Characteristic Curves**

All test conditions are at 25°C The figures are identical for MSCWI03-48S12

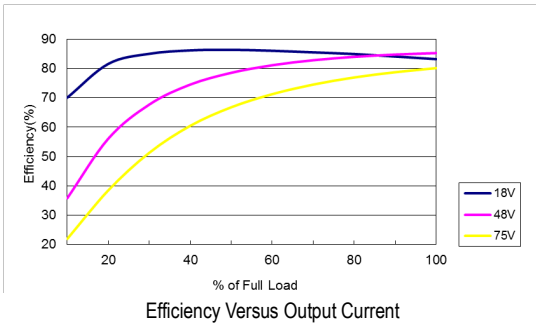

Efficiency Versus Output Current

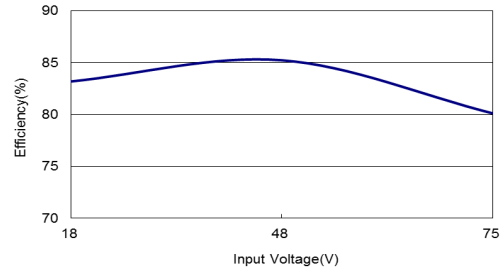

Efficiency Versus Input Voltage  
Full Load

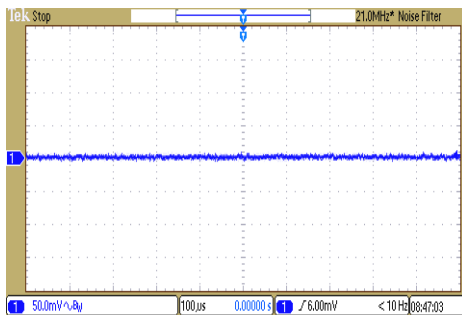

Typical Output Ripple and Noise  
 $V_{in}=V_{in\ nom}$ ; Full Load

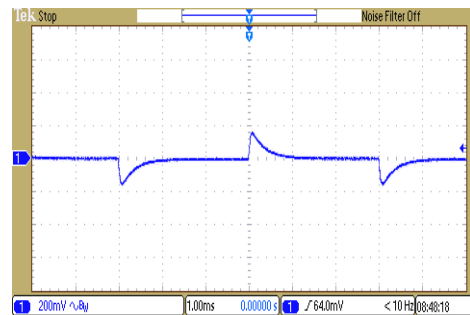

Transient Response to Dynamic Load Change  
from 100% to 75% of Full Load ;  $V_{in}=V_{in\ nom}$



Typical Input Start-Up and Output Rise Characteristic  
 $V_{in}=V_{in\ nom}$ ; Full Load

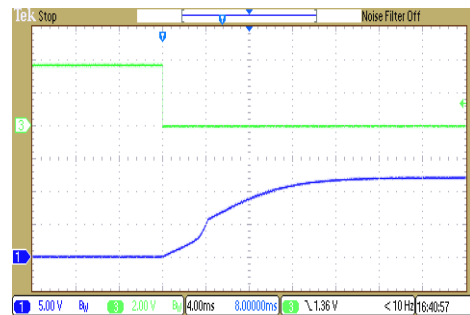

ON/OFF Voltage Start-Up and Output Rise Characteristic  
 $V_{in}=V_{in\ nom}$ ; Full Load

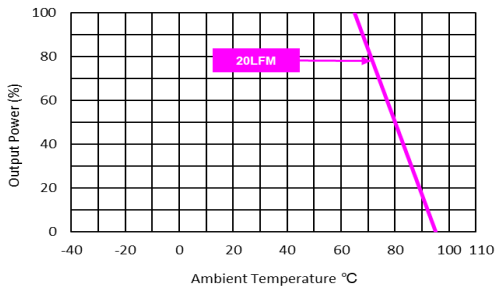

Derating Output Current Versus Ambient Temperature and Airflow  
 $V_{in}=V_{in\ nom}$

**Characteristic Curves**

All test conditions are at 25°C The figures are identical for MSCWI03-48S15

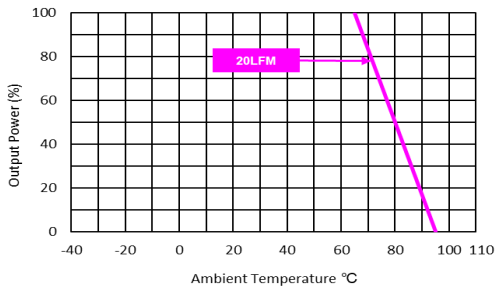
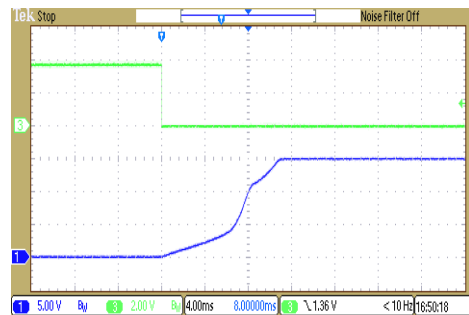
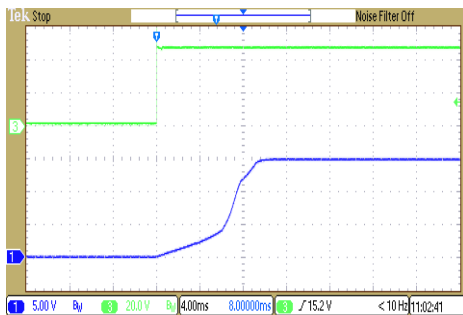
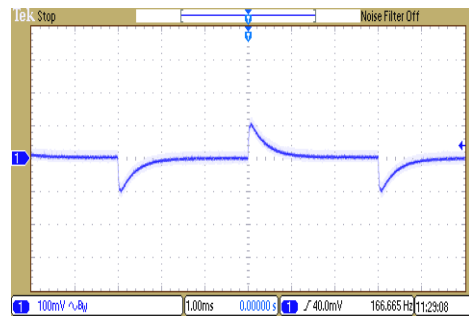
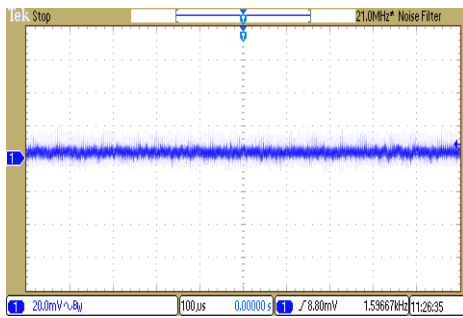
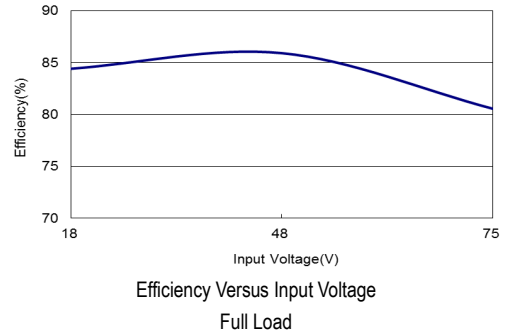
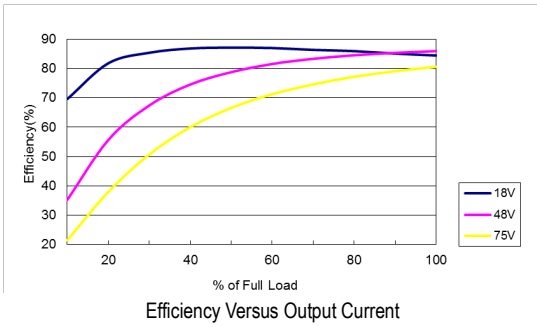

**Characteristic Curves**

All test conditions are at 25°C The figures are identical for MSCWI03-48S24

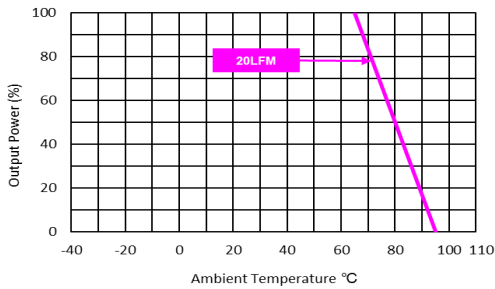
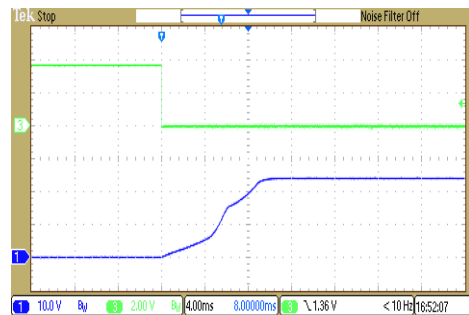
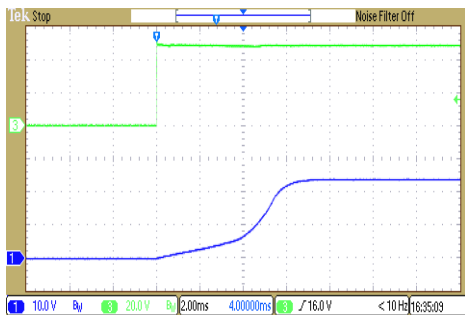
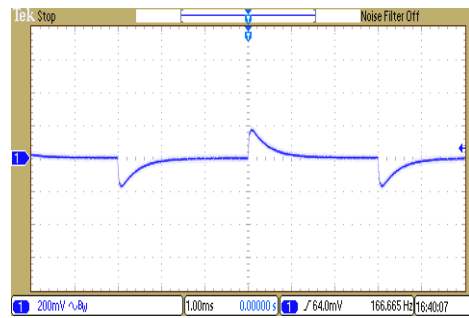
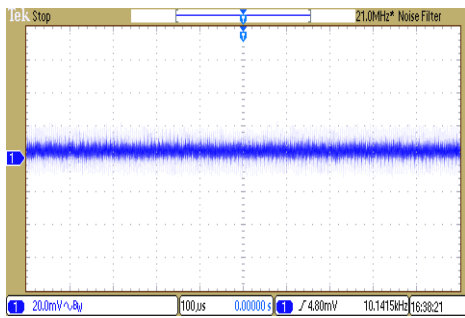
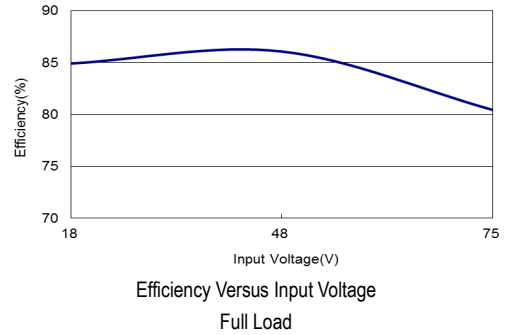
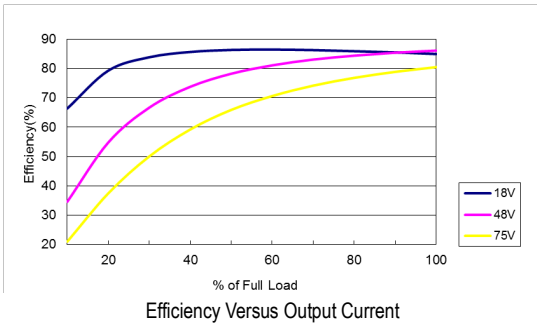

**Characteristic Curves**

All test conditions are at 25°C The figures are identical for MSCWI03-48D12

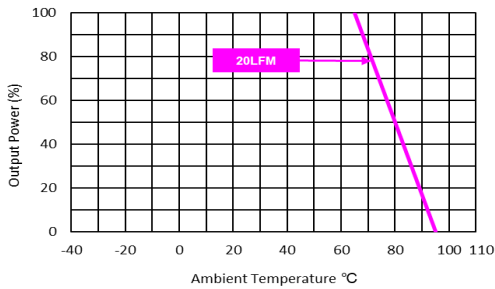
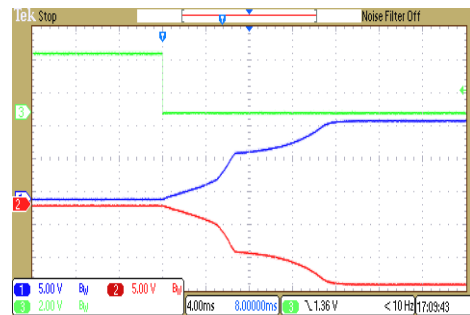
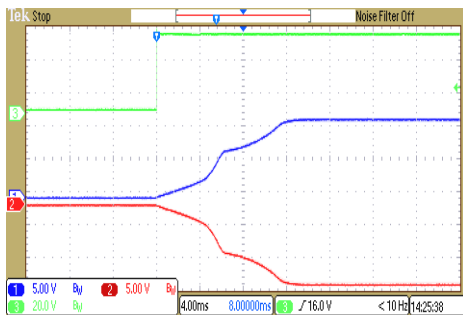
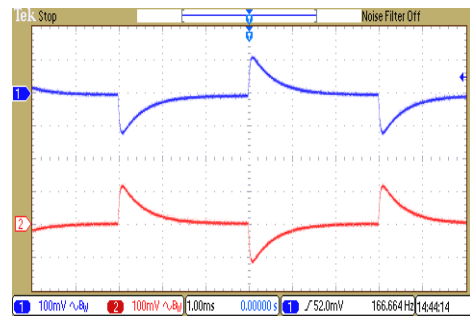
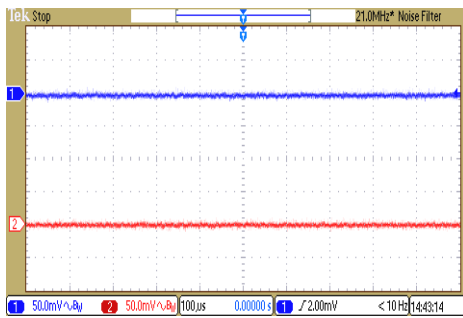
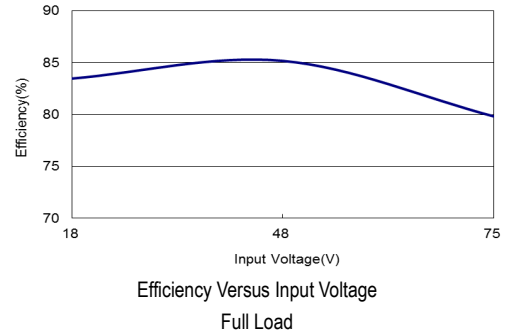
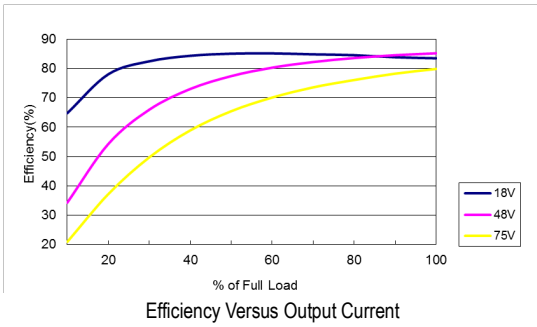



**Characteristic Curves**

All test conditions are at 25°C The figures are identical for MSCWI03-48D15

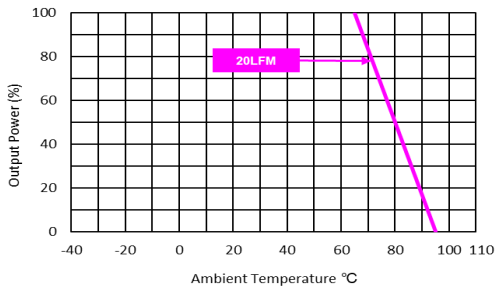
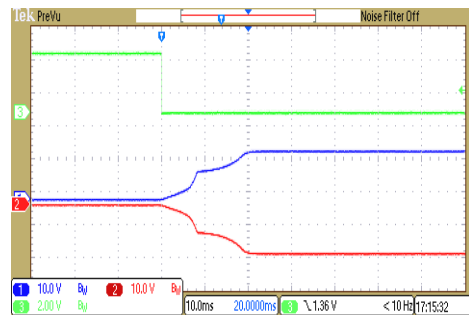
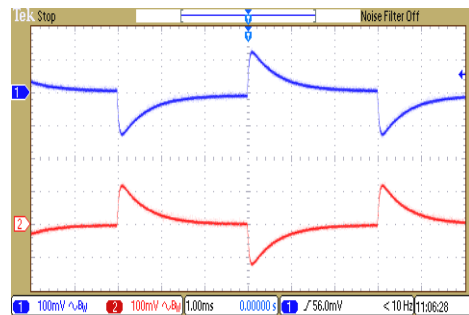
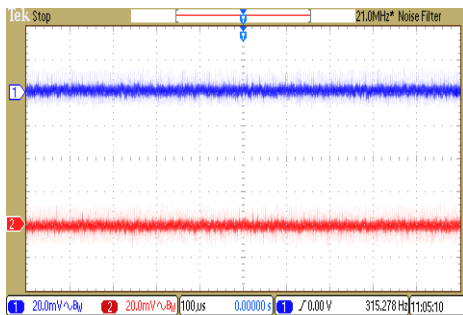
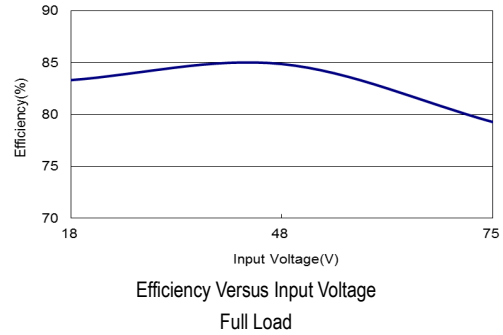
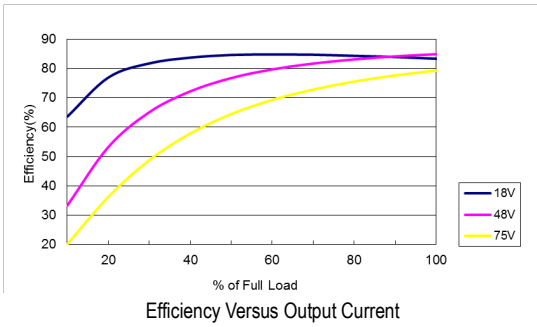



### Package Specifications

#### Mechanical Dimensions

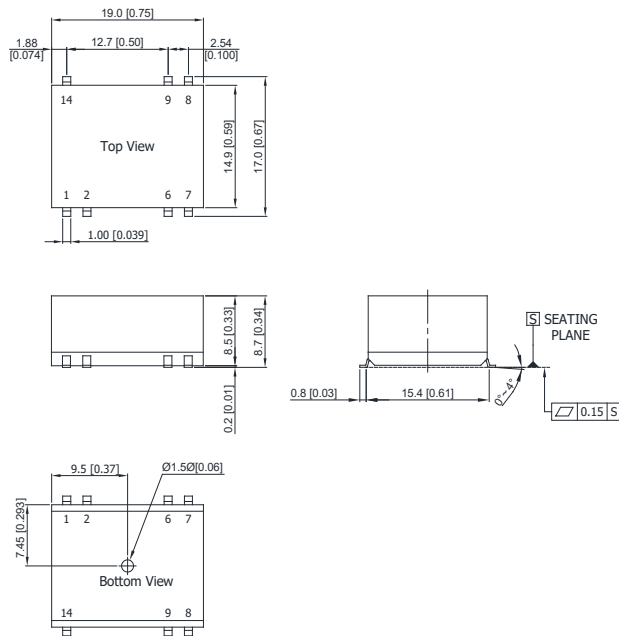

#### Connecting Pin Patterns

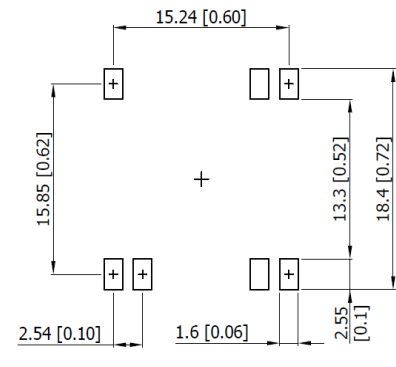

- ▶ All dimensions in mm (inches)
- ▶ Tolerance: X.X±0.5 (X.XX±0.02)  
X.XX±0.25 (X.XXX±0.01)
- ▶ Pins ±0.05(±0.002)

#### Pin Connections

Pin	Single Output	Dual Output
1	-Vin	-Vin
2	Remote On/Off	Remote On/Off
6	NC	Common
7	NC	-Vout
8	+Vout	+Vout
9	-Vout	Common
14	+Vin	+Vin

NC: No Connection

#### Physical Characteristics

Case Size	: 19.0x14.9x8.5mm (0.75x0.59x0.33 inches)
Case Material	: Plastic resin (flammability to UL 94V-0 rated)
Pin Material	: Phosphor Bronze
Weight	: 3.5g

## Test Setup

### Peak-to-Peak Output Noise Measurement Test

Refer to the output specifications or add 4.7 $\mu$ F capacitor if the output specifications undefine Cout. Scope measurement should be made by using a BNC socket, measurement bandwidth is 0-20 MHz. Position the load between 50 mm and 75 mm from the DC-DC Converter.

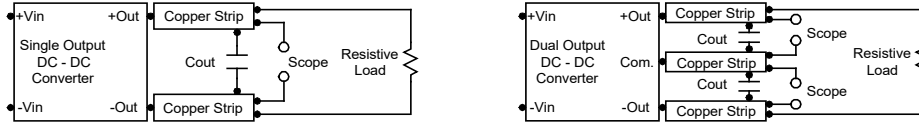

## Technical Notes

### Remote On/Off

Only one type of remote ON/OFF control is available for MSCWI03. The module will turn on during the ON/OFF pin open or high impedance between ON/OFF pin and -Vin pin. The module will turn off if the ON/OFF pin is applied with a current of 2~4mA.

### Maximum Capacitive Load

The MSCWI03 series has limitation of maximum connected capacitance at the output. The power module may be operated in current limiting mode during start-up, affecting the ramp-up and the startup time. The maximum capacitance can be found in the data sheet.

### Overload Protection

To provide protection in a fault (output overload) condition, the unit is equipped with internal current limiting circuitry and can endure current limiting for an unlimited duration. At the point of current-limit inception, the unit shifts from voltage control to current control. The unit operates normally once the output current is brought back into its specified range.

### Input Source Impedance

The power module should be connected to a low ac-impedance input source. Highly inductive source impedances can affect the stability of the power module. In applications where power is supplied over long lines and output loading is high, it may be necessary to use a capacitor at the input to ensure startup. Capacitor mounted close to the power module helps ensure stability of the unit, it is commended to use a good quality low Equivalent Series Resistance (ESR < 1.0 $\Omega$  at 100 kHz) capacitor of a 4.7 $\mu$ F for the 5V input devices and a 2.2 $\mu$ F for the 24V and 48V devices.

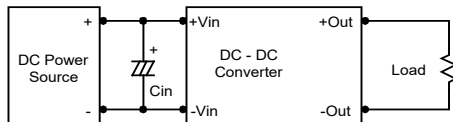

### Output Ripple Reduction

A good quality low ESR capacitor placed as close as practicable across the load will give the best ripple and noise performance. To reduce output ripple, it is recommended to use 3.3 $\mu$ F capacitors at the output.

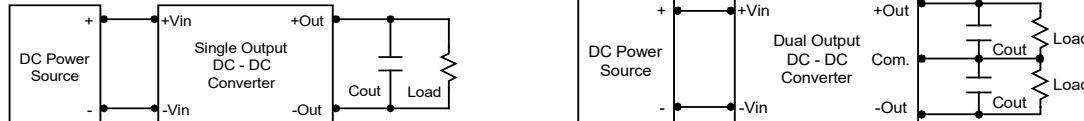

### Thermal Considerations

Many conditions affect the thermal performance of the power module, such as orientation, airflow over the module and board spacing. To avoid exceeding the maximum temperature rating of the components inside the power module, the case temperature must be kept below 95 $^{\circ}$ C. The derating curves are determined from measurements obtained in a test setup.

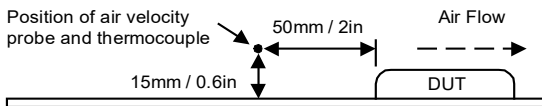

**Remote On/Off Implementation**

Only one type of remote ON/OFF control is available for MSCWI03. The module will turn on during the ON/OFF pin open or high impedance between ON/OFF pin and -Vin pin. The module will turn off if the ON/OFF pin is applied with a current of 2~4mA.

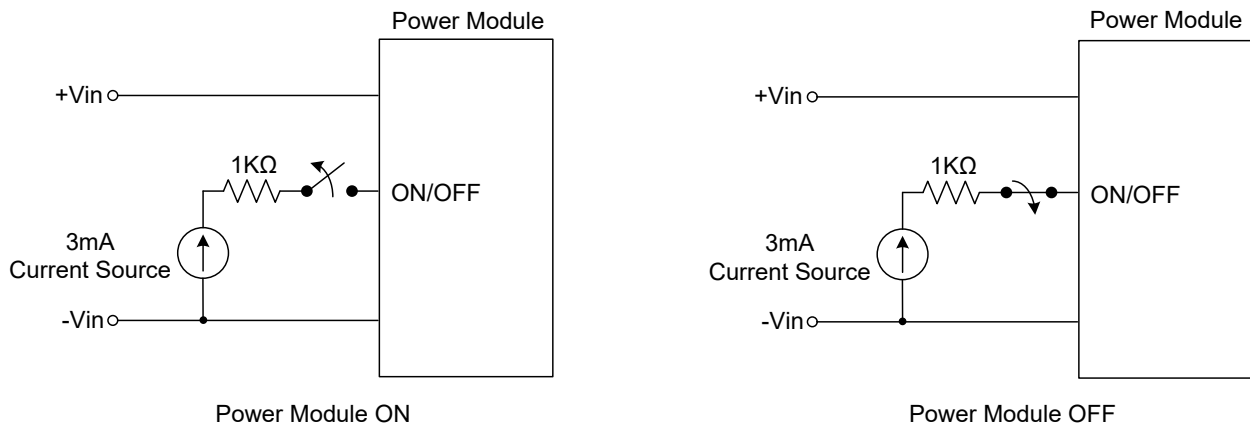

**Packaging Information for Tube**

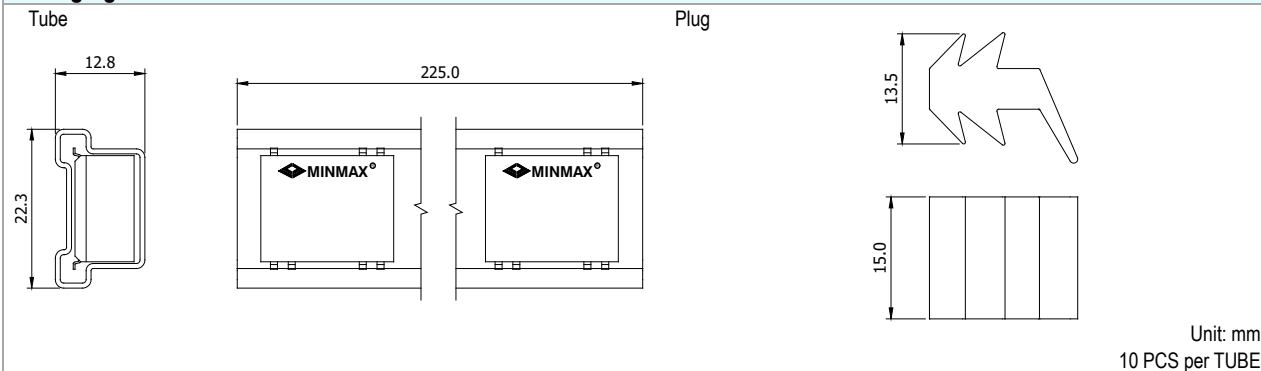

**Packaging Information for Tape & Reel**

Tape

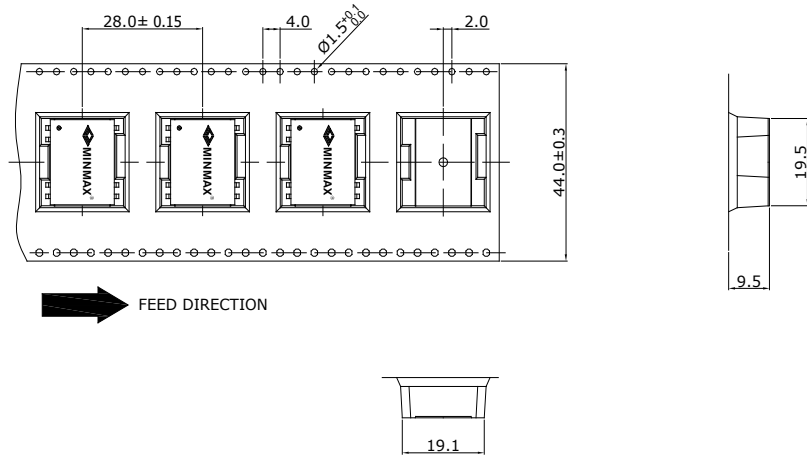

Reel

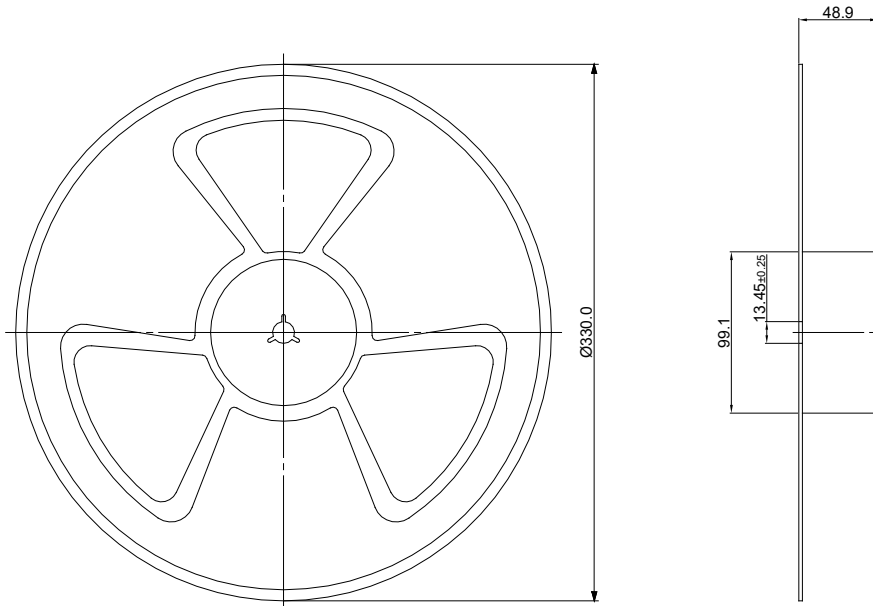

Packaging Style	Quantity
With Heatsink Tube	N/A
Tape and Reel to IEC 286-3 Specifications	250

**Soldering and Reflow Considerations**

Profile	Sn-Pb Eutectic Assembly	Pb-Free Assembly
Average ramp-up rate( $T_s$ max. To $T_p$ )	3°C/second max.	3°C/second max.
Preheat		
· Temperature Min ( $T_{smin}$ )	100°C	150°C
· Temperature Max ( $T_{smax}$ )	150°C	200°C
· Time ( $T_{smin}$ to $T_{smax}$ ) (ts)	60~120 seconds	60~180 seconds
Time maintained above:		
· Temperature ( $T_L$ )	183°C	217°C
· Time ( $t_L$ )	60~150 seconds	60~150 seconds
Peak Temperature ( $T_p$ )	See Table 4-1	See Table 4-2
Time within 5°C of actual Peak Temperature ( $t_p$ ) <sup>2</sup>	10~30 seconds	20~40 seconds
Ramp-down Rate	6°C/second max.	6°C/second max.
Time 25°C to Peak Temperature	6 minutes max.	8 minutes max.

Note 1: All temperatures refer to topside of the package, measured on the package body surface.

Note 2: Time within 5°C of actual peak temperature ( $t_p$ ) specified for the reflow profiles is a "supplier" minimum and "user" maximum.

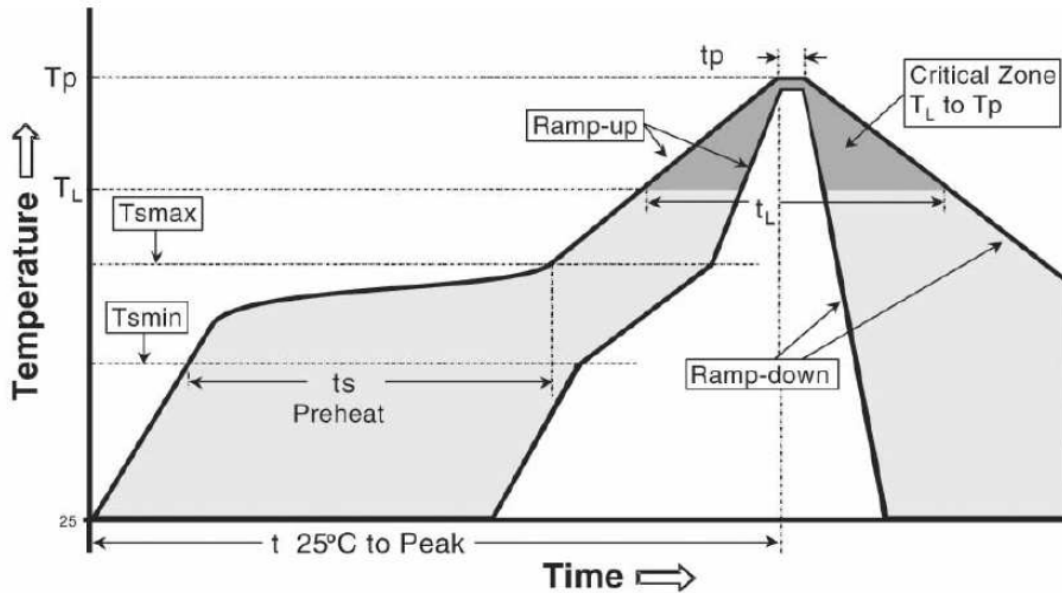

Table 4-1 SnPb Eutectic Process-Classification Temperatures ( $T_c$ )

Package Thickness	Volume mm <sup>3</sup>	Volume mm <sup>3</sup>
<2.5mm	<350	≥350
≥2.5mm	235°C	220°C
	220°C	220°C

Table 4-2 Pb-Free Process-Classification Temperatures ( $T_c$ )

Package Thickness	Volume mm <sup>3</sup>	Volume mm <sup>3</sup>	Volume mm <sup>3</sup>
<1.6mm	<350	350-2000	>2000
1.6mm-2.5mm	260°C	260°C	260°C
>2.5mm	260°C	250°C	245°C
	250°C	245°C	245°C

**Part Number Structure**

<b>M</b>	<b>SC</b>	<b>WI</b>	<b>03</b>	-	<b>05</b>	<b>S</b>	<b>05</b>
<b>Package Type</b> SMD-14	<b>Ultra-wide 4:1</b> Input Voltage Range	<b>Output Power</b> 3 Watt	<b>Input Voltage Range</b>			<b>Output Quantity</b>	<b>Output Voltage</b>
			05: 4.5 ~ 12 VDC		S: Single	05: 5 VDC	
			24: 9 ~ 36 VDC		D: Dual	12: 12 VDC	
			48: 18 ~ 75 VDC			15: 15 VDC	
						24: 24 VDC	

**MTBF and Reliability**

The MTBF of MSCWI03 series of DC-DC converters has been calculated using

MIL-HDBK 217F NOTICE2, Operating Temperature 25°C, Ground Benign.

Model	MTBF	Unit
MSCWI03-05S05	5,519,000	Hours
MSCWI03-05S12	5,563,000	
MSCWI03-05S15	5,621,000	
MSCWI03-05S24	5,624,000	
MSCWI03-05D12	5,309,000	
MSCWI03-05D15	5,086,000	
MSCWI03-24S05	5,638,000	
MSCWI03-24S12	5,786,000	
MSCWI03-24S15	5,622,000	
MSCWI03-24S24	5,892,000	
MSCWI03-24D12	5,525,000	
MSCWI03-24D15	5,279,000	
MSCWI03-48S05	5,566,000	
MSCWI03-48S12	5,701,000	
MSCWI03-48S15	5,463,000	
MSCWI03-48S24	5,774,000	
MSCWI03-48D12	5,441,000	
MSCWI03-48D15	5,228,000	