



MCWI03 Series

DC-DC CONVERTER 3W, SIP Package

Features

- ▶ Compact SIP-8 Package
- ▶ Ultra-wide 4 : 1 Input Voltage Range
- ▶ Fully Regulated Output Voltage
- ▶ I/O Isolation 1600 VDC
- ▶ Operating Ambient Temp. Range -40°C to +85°C
- ▶ Overload and Short Circuit Protection
- ▶ Remote On/Off Control
- ▶ UL/cUL/IEC/EN 62368-1(60950-1) Safety Approval

Applications

- ▶ Distributed power architectures
- ▶ Workstations
- ▶ Computer equipment
- ▶ Communications equipment

Product Overview

The MINMAX MCWI03 series is a range of isolated 3W DC-DC converter modules featuring fully regulated output and ultra-wide 4:1 input voltage ranges. The product comes in a SIP-8 package with a very small footprint occupying only 2.0 cm² (0.3 square in.) on the PCB. An excellent efficiency allows an operating temperature range of -40°C to +85°C. Further features include remote On/Off control and over load protection. The very compact dimensions of these DC-DC converters make them an ideal solution for many space critical applications in battery-powered equipment and instrumentation.

Electric Characteristic Note



Table of contents

| | | | |
|----------------------------------------------------------------|-----|------------------------------------|-----|
| Model Selection Guide..... | P2 | Test Setup..... | P26 |
| Input Specifications..... | P2 | Technical Notes..... | P26 |
| Remote On/Off Control..... | P2 | Remote ON/OFF Implementation..... | P27 |
| Output Specifications..... | P3 | Packaging Information..... | P28 |
| General Specifications..... | P3 | Wave Soldering Considerations..... | P28 |
| Environmental Specifications..... | P3 | Hand Welding Parameter..... | P28 |
| Characteristic Curves..... | P4 | Part Number Structure..... | P29 |
| Package Specifications..... | P25 | MTBF and Reliability..... | P29 |
| Recommended Pad Layout for Single & Dual Output Converter..... | P25 | | |

| Model Selection Guide | | | | | | | | |
|-----------------------|-----------------------|----------------|----------------|------|---------------|----------|----------------------|-------------------|
| Model Number | Input Voltage (Range) | Output Voltage | Output Current | | Input Current | | Max. capacitive Load | Efficiency (typ.) |
| | | | Max. | Min. | @Max. Load | @No Load | | @Max. Load |
| | VDC | VDC | mA | mA | mA(typ.) | mA(typ.) | μF | % |
| MCWI03-12S033 | 12 (4.5 ~ 18) | 3.3 | 700 | 175 | 260 | 60 | 1760 | 74 |
| MCWI03-12S05 | | 5 | 600 | 150 | 320 | | 1000 | 78 |
| MCWI03-12S12 | | 12 | 250 | 63 | 313 | | 170 | 80 |
| MCWI03-12S15 | | 15 | 200 | 50 | 313 | | 110 | 80 |
| MCWI03-12D05 | | ±5 | ±300 | ±75 | 313 | | 470 # | 80 |
| MCWI03-12D12 | | ±12 | ±125 | ±31 | 313 | | 100 # | 80 |
| MCWI03-12D15 | | ±15 | ±100 | ±25 | 313 | | 47 # | 80 |
| MCWI03-24S033 | 24 (9 ~ 36) | 3.3 | 700 | 175 | 128 | 25 | 1760 | 75 |
| MCWI03-24S05 | | 5 | 600 | 150 | 156 | | 1000 | 80 |
| MCWI03-24S12 | | 12 | 250 | 63 | 154 | | 170 | 81 |
| MCWI03-24S15 | | 15 | 200 | 50 | 154 | | 110 | 81 |
| MCWI03-24D05 | | ±5 | ±300 | ±75 | 158 | | 470 # | 79 |
| MCWI03-24D12 | | ±12 | ±125 | ±31 | 156 | | 100 # | 80 |
| MCWI03-24D15 | | ±15 | ±100 | ±25 | 154 | | 47 # | 81 |
| MCWI03-48S033 | 48 (18 ~ 75) | 3.3 | 700 | 175 | 65 | 15 | 1760 | 74 |
| MCWI03-48S05 | | 5 | 600 | 150 | 79 | | 1000 | 79 |
| MCWI03-48S12 | | 12 | 250 | 63 | 79 | | 170 | 79 |
| MCWI03-48S15 | | 15 | 200 | 50 | 79 | | 110 | 79 |
| MCWI03-48D05 | | ±5 | ±300 | ±75 | 79 | | 470 # | 79 |
| MCWI03-48D12 | | ±12 | ±125 | ±31 | 79 | | 100 # | 79 |
| MCWI03-48D15 | | ±15 | ±100 | ±25 | 78 | | 47 # | 80 |

For each output

| Input Specifications | | | | | |
|-----------------------------------|------------------|--------------------|------|------|------|
| Parameter | Model | Min. | Typ. | Max. | Unit |
| Input Surge Voltage (1 sec. max.) | 12V Input Models | -0.7 | --- | 25 | VDC |
| | 24V Input Models | -0.7 | --- | 50 | |
| | 48V Input Models | -0.7 | --- | 100 | |
| Start-Up Threshold Voltage | 12V Input Models | 3 | 4 | 4.5 | |
| | 24V Input Models | 4.5 | 6 | 9 | |
| | 48V Input Models | 8.5 | 12 | 18 | |
| Under Voltage Shutdown | 12V Input Models | --- | 3.5 | 4 | |
| | 24V Input Models | --- | --- | 8 | |
| | 48V Input Models | --- | --- | 16 | |
| Short Circuit Input Power | All Models | --- | --- | 2500 | mW |
| Input Filter | | Internal Capacitor | | | |

| Remote On/Off Control | | | | | | |
|-------------------------------|-------------------------------|------|------|------|------|--|
| Parameter | Conditions | Min. | Typ. | Max. | Unit | |
| Converter On | Under 0.6 VDC or Open Circuit | | | | | |
| Converter Off | 2.7 to 15 VDC | | | | | |
| Device Standby Input Current | Nominal Vin | --- | --- | 3 | mA | |
| Control Input Current (on) | Vin = 0V | --- | --- | 1 | mA | |
| Control Input Current (off) | Vin = 5.0V | --- | --- | 1 | mA | |
| Control Common | Referenced to Negative Input | | | | | |

| Output Specifications | | | | | |
|---------------------------------|--------------------------------|------|------|-------|-------------------|
| Parameter | Conditions | Min. | Typ. | Max. | Unit |
| Output Voltage Setting Accuracy | | --- | --- | ±1.0 | %Vnom. |
| Output Voltage Balance | Dual Output, Balanced Loads | --- | ±0.5 | ±2.0 | % |
| Line Regulation | Vin=Min. to Max. @Full Load | --- | ±0.3 | ±0.5 | % |
| Load Regulation | Io=25% to 100% | --- | ±0.5 | ±1.0 | % |
| Ripple & Noise | 0-20 MHz Bandwidth | --- | --- | 75 | mV _{P-P} |
| Transient Recovery Time | 25% Load Step Change | --- | 300 | 500 | µsec |
| Transient Response Deviation | | --- | ±3 | ±5 | % |
| Temperature Coefficient | | --- | --- | ±0.02 | %/°C |
| Over Load Protection | Foldback | 110 | 140 | --- | % |
| Short Circuit Protection | Continuous, Automatic Recovery | | | | |

| General Specifications | | | | | |
|---------------------------|------------------------------------------------------------------------|---------|------|------|-------|
| Parameter | Conditions | Min. | Typ. | Max. | Unit |
| I/O Isolation Voltage | 60 Seconds | 1600 | --- | --- | VDC |
| | 1 Second | 1920 | --- | --- | VDC |
| I/O Isolation Resistance | 500 VDC | 1000 | --- | --- | MΩ |
| I/O Isolation Capacitance | 100kHz, 1V | --- | 200 | --- | pF |
| Switching Frequency | | --- | 350 | --- | kHz |
| MTBF (calculated) | MIL-HDBK-217F@25°C, Ground Benign | 800,000 | | | Hours |
| Safety Approvals | UL/cUL 60950-1 recognition(CSA certificate), IEC/EN 60950-1(CB-report) | | | | |
| | UL/cUL 62368-1 recognition(UL certificate), IEC/EN 62368-1(CB-report) | | | | |

| Environmental Specifications | | | | |
|----------------------------------------------------------------|------|------|----------|--|
| Parameter | Min. | Max. | Unit | |
| Operating Ambient Temperature Range (See Power Derating Curve) | -40 | +85 | °C | |
| Case Temperature | --- | 105 | °C | |
| Storage Temperature Range | -55 | +125 | °C | |
| Humidity (non condensing) | --- | 95 | % rel. H | |
| Lead Temperature (1.5mm from case for 10Sec.) | --- | 260 | °C | |

- Notes**
- Specifications typical at Ta=+25°C, resistive load, nominal input voltage and rated output current unless otherwise noted.
 - Transient recovery time is measured to within 1% error band for a step change in output load of 75% to 100%.
 - Ripple & Noise measured with a 1µF/50V M/C.
 - These power converters require a minimum output loading to maintain specified regulation, operation under no-load conditions will not damage these modules; however, they may not meet all specifications listed.
 - We recommend to protect the converter by a slow blow fuse in the input supply line.
 - Other input and output voltage may be available, please contact MINMAX.
 - Specifications are subject to change without notice.

Characteristic Curves

All test conditions are at 25°C The figures are identical for MCWI03-12S033

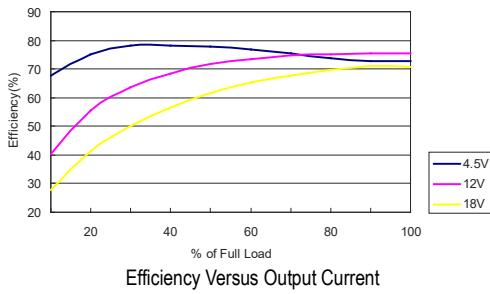

Efficiency Versus Output Current

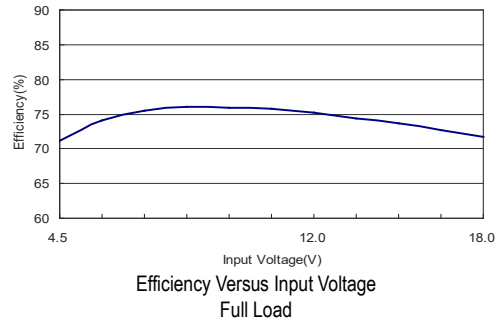

Efficiency Versus Input Voltage Full Load

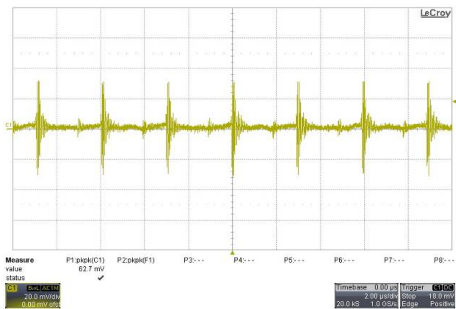

Typical Output Ripple and Noise
 $V_{in}=V_{in\ nom}$; Full Load

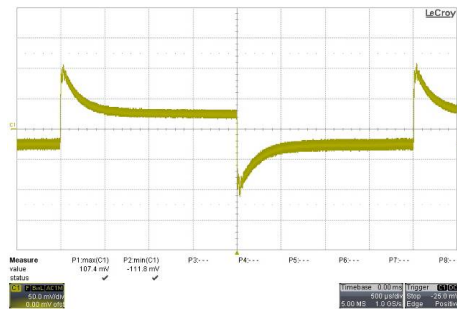

Transient Response to Dynamic Load Change
from 100% to 75% of Full Load ; $V_{in}=V_{in\ nom}$

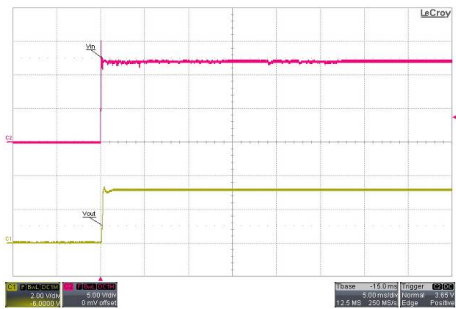

Typical Input Start-Up and Output Rise Characteristic
 $V_{in}=V_{in\ nom}$; Full Load

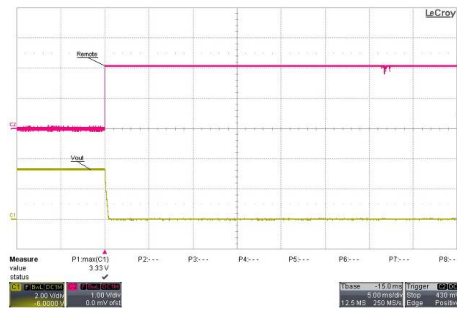

ON/OFF Voltage Start-Up and Output Rise Characteristic
 $V_{in}=V_{in\ nom}$; Full Load

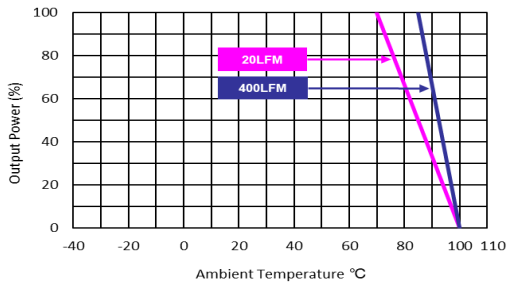

Derating Output Current Versus Ambient Temperature and Airflow
 $V_{in}=V_{in\ nom}$

Characteristic Curves

All test conditions are at 25°C The figures are identical for MCWI03-12S05

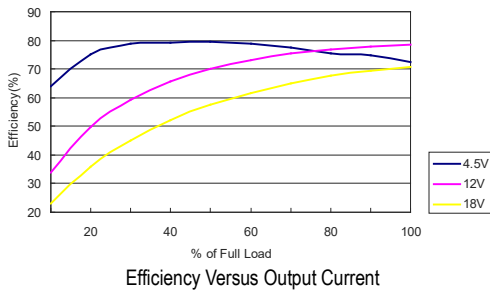

Efficiency Versus Output Current

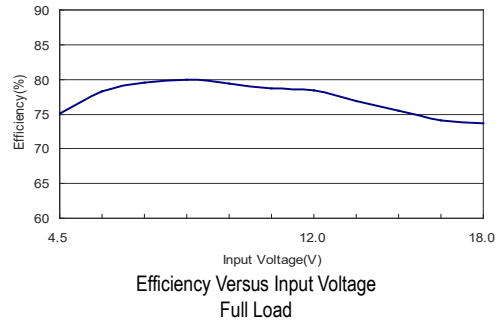

Efficiency Versus Input Voltage Full Load

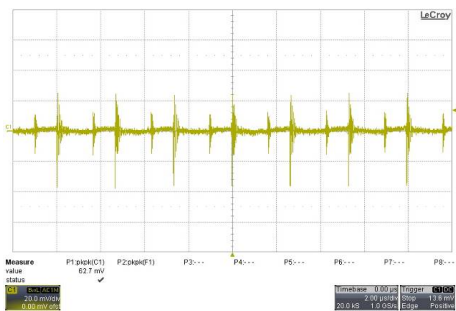

Typical Output Ripple and Noise
 $V_{in}=V_{in\ nom}$; Full Load

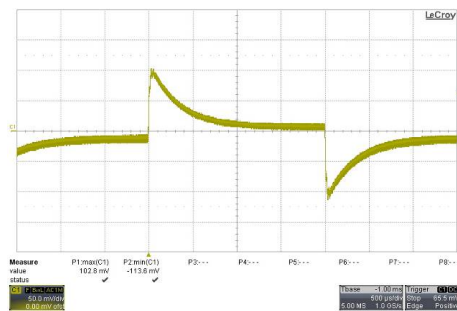

Transient Response to Dynamic Load Change
from 100% to 75% of Full Load ; $V_{in}=V_{in\ nom}$

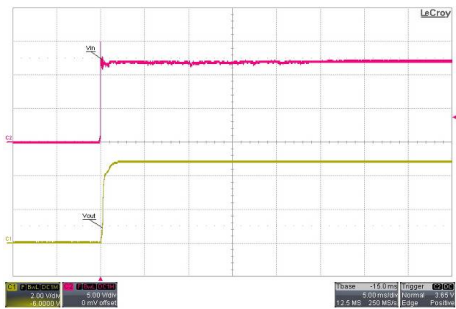

Typical Input Start-Up and Output Rise Characteristic
 $V_{in}=V_{in\ nom}$; Full Load

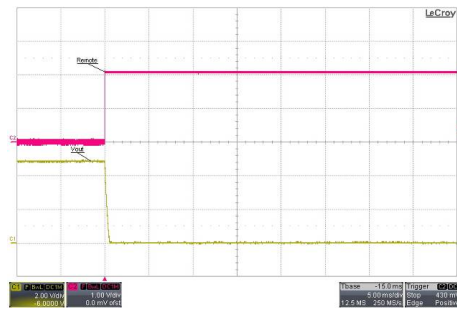

ON/OFF Voltage Start-Up and Output Rise Characteristic
 $V_{in}=V_{in\ nom}$; Full Load

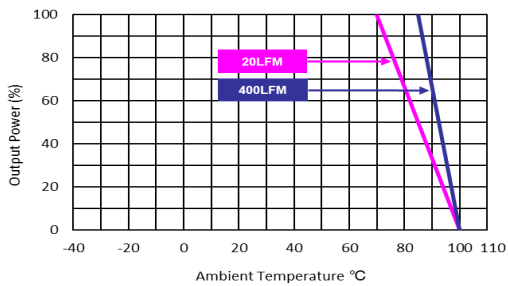

Derating Output Current Versus Ambient Temperature and Airflow
 $V_{in}=V_{in\ nom}$

Characteristic Curves

All test conditions are at 25°C The figures are identical for MCWI03-12S12

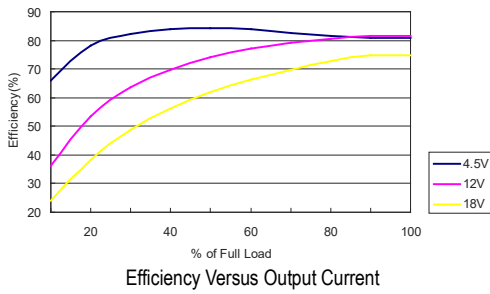

Efficiency Versus Output Current

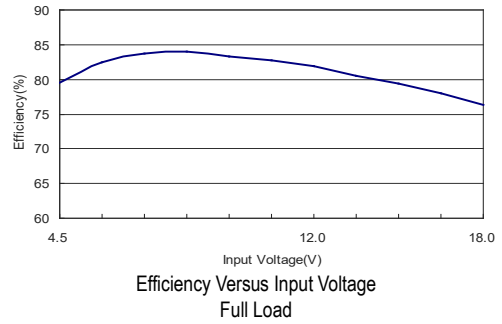

Efficiency Versus Input Voltage Full Load

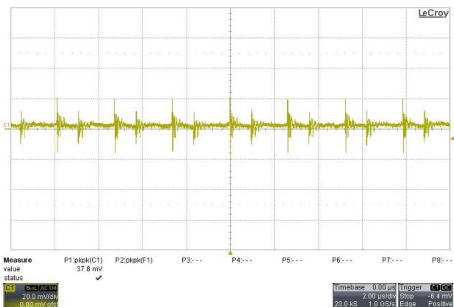

Typical Output Ripple and Noise
 $V_{in}=V_{in\ nom}$; Full Load

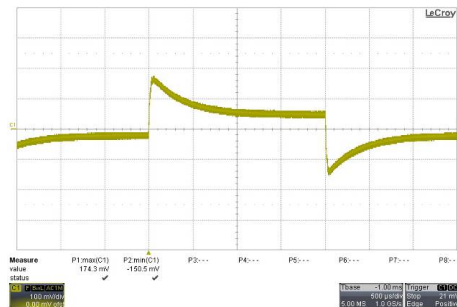

Transient Response to Dynamic Load Change
from 100% to 75% of Full Load ; $V_{in}=V_{in\ nom}$



Typical Input Start-Up and Output Rise Characteristic
 $V_{in}=V_{in\ nom}$; Full Load



ON/OFF Voltage Start-Up and Output Rise Characteristic
 $V_{in}=V_{in\ nom}$; Full Load

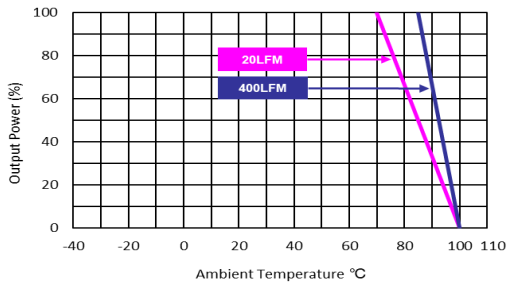

Derating Output Current Versus Ambient Temperature and Airflow
 $V_{in}=V_{in\ nom}$

Characteristic Curves

All test conditions are at 25°C The figures are identical for MCWI03-12S15

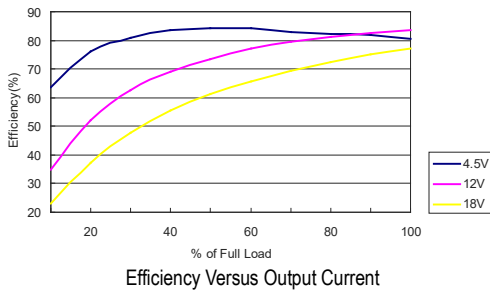

Efficiency Versus Output Current

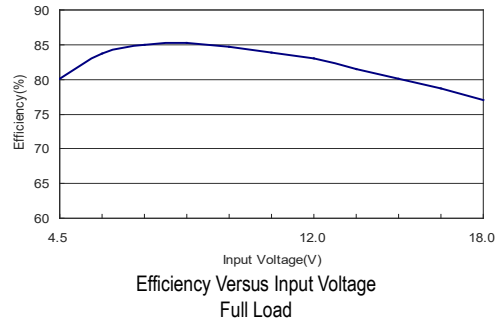

Efficiency Versus Input Voltage Full Load

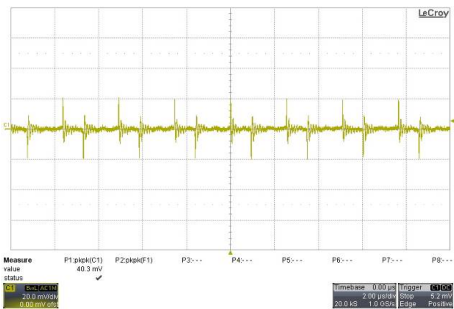

Typical Output Ripple and Noise
 $V_{in}=V_{in\ nom}$; Full Load

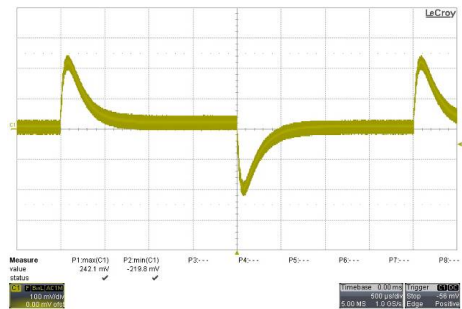

Transient Response to Dynamic Load Change
from 100% to 75% of Full Load ; $V_{in}=V_{in\ nom}$

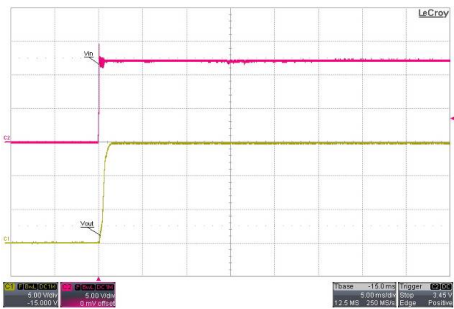

Typical Input Start-Up and Output Rise Characteristic
 $V_{in}=V_{in\ nom}$; Full Load

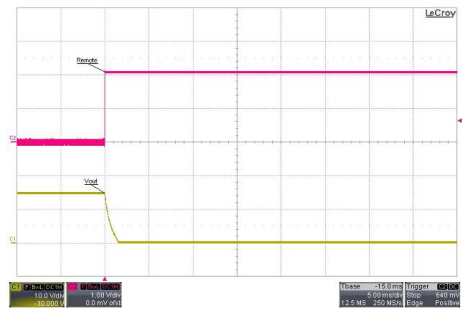

ON/OFF Voltage Start-Up and Output Rise Characteristic
 $V_{in}=V_{in\ nom}$; Full Load

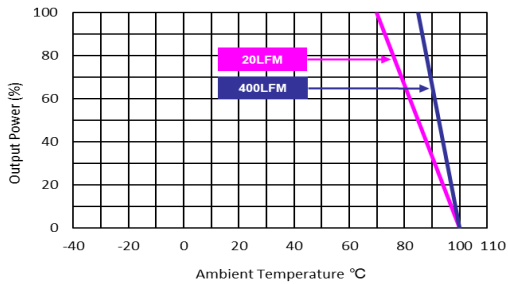

Derating Output Current Versus Ambient Temperature and Airflow
 $V_{in}=V_{in\ nom}$

Characteristic Curves

All test conditions are at 25°C The figures are identical for MCWI03-12D05

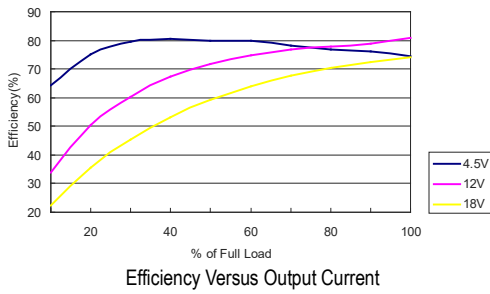

Efficiency Versus Output Current

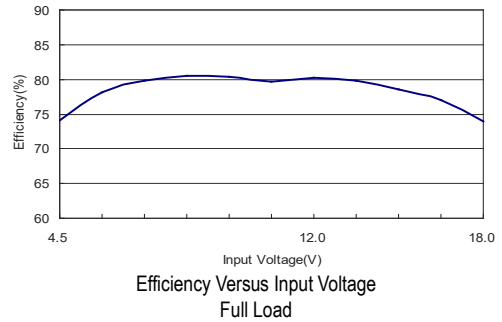

Efficiency Versus Input Voltage Full Load

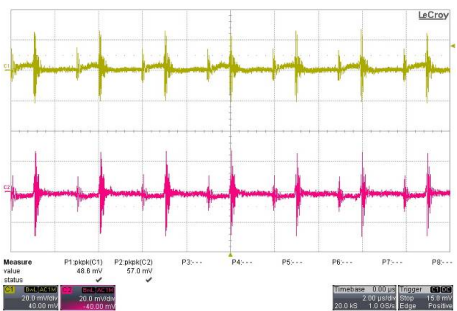

Typical Output Ripple and Noise
 $V_{in}=V_{in\ nom}$; Full Load

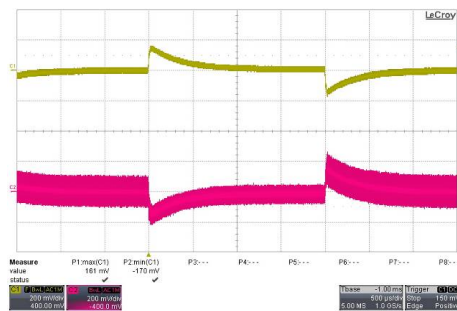

Transient Response to Dynamic Load Change
from 100% to 75% of Full Load ; $V_{in}=V_{in\ nom}$

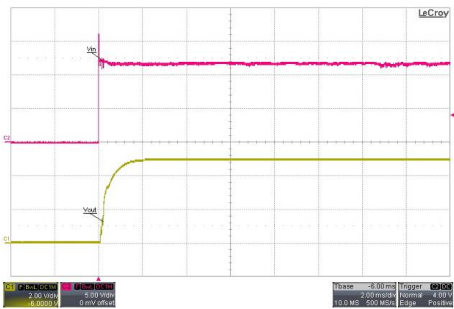

Typical Input Start-Up and Output Rise Characteristic
 $V_{in}=V_{in\ nom}$; Full Load

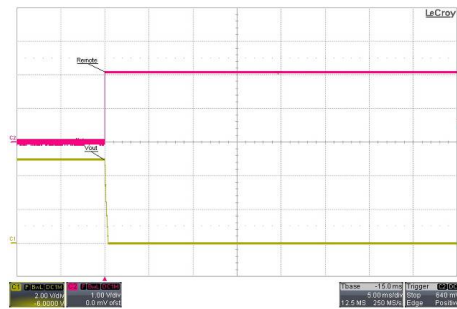

ON/OFF Voltage Start-Up and Output Rise Characteristic
 $V_{in}=V_{in\ nom}$; Full Load

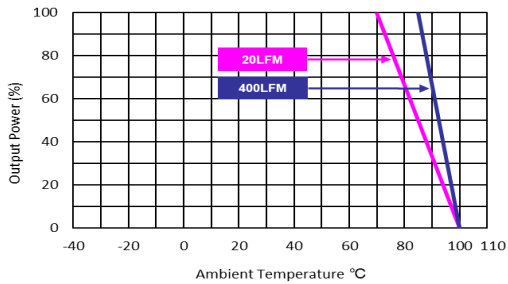

Derating Output Current Versus Ambient Temperature and Airflow
 $V_{in}=V_{in\ nom}$

Characteristic Curves

All test conditions are at 25°C The figures are identical for MCWI03-12D12

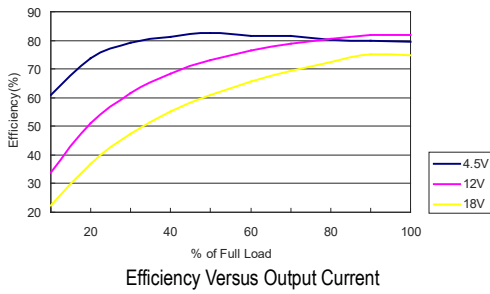

Efficiency Versus Output Current

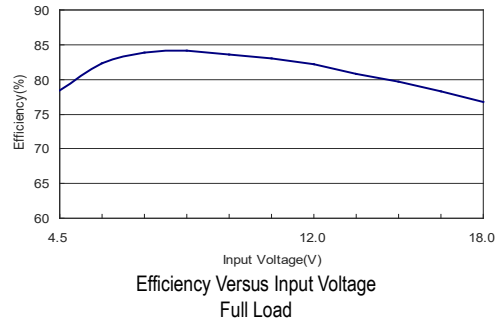

Efficiency Versus Input Voltage Full Load

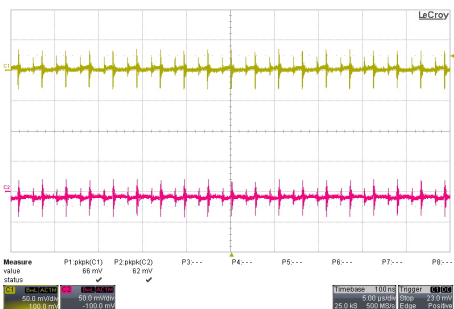

Typical Output Ripple and Noise
 $V_{in}=V_{in\ nom}$; Full Load



Transient Response to Dynamic Load Change
from 100% to 75% of Full Load ; $V_{in}=V_{in\ nom}$

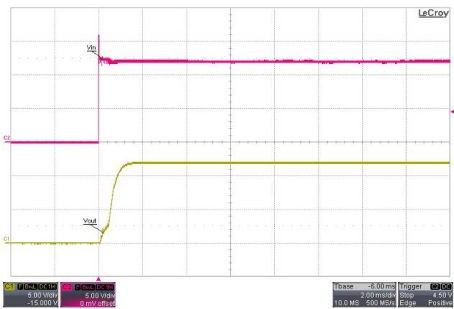

Typical Input Start-Up and Output Rise Characteristic
 $V_{in}=V_{in\ nom}$; Full Load



ON/OFF Voltage Start-Up and Output Rise Characteristic
 $V_{in}=V_{in\ nom}$; Full Load

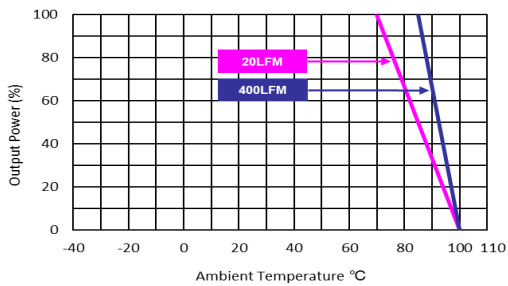

Derating Output Current Versus Ambient Temperature and Airflow
 $V_{in}=V_{in\ nom}$

Characteristic Curves

All test conditions are at 25°C The figures are identical for MCWI03-12D15

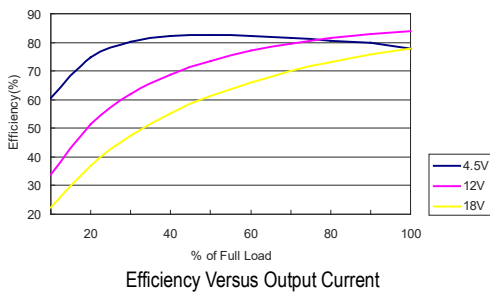

Efficiency Versus Output Current

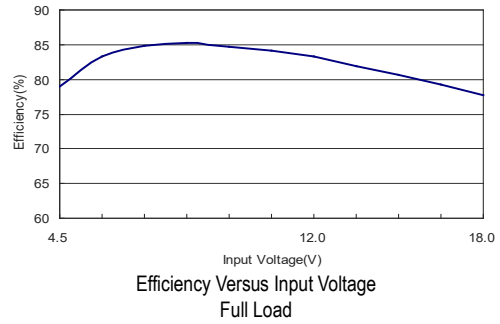

Efficiency Versus Input Voltage Full Load

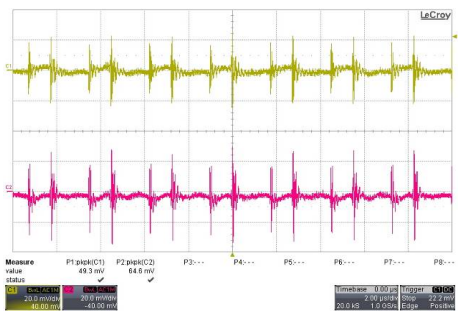

Typical Output Ripple and Noise
 $V_{in}=V_{in\ nom}$; Full Load

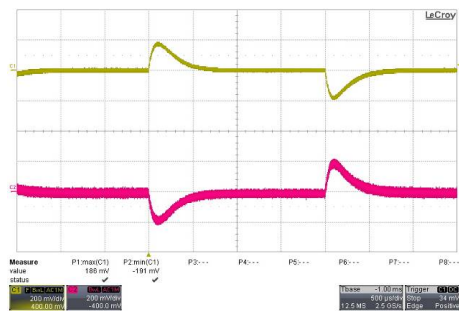

Transient Response to Dynamic Load Change
from 100% to 75% of Full Load ; $V_{in}=V_{in\ nom}$



Typical Input Start-Up and Output Rise Characteristic
 $V_{in}=V_{in\ nom}$; Full Load

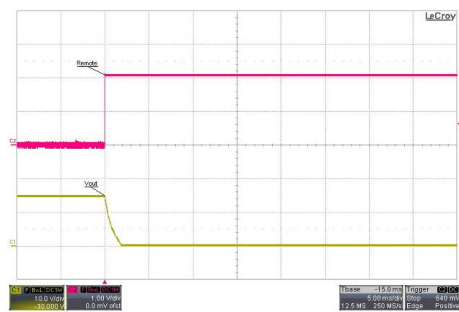

ON/OFF Voltage Start-Up and Output Rise Characteristic
 $V_{in}=V_{in\ nom}$; Full Load

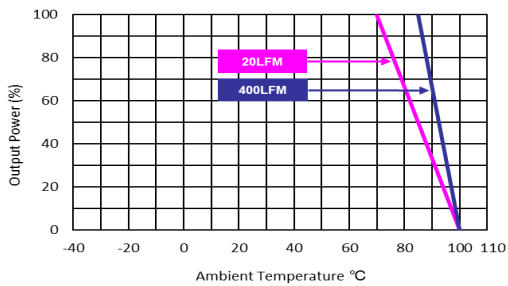

Derating Output Current Versus Ambient Temperature and Airflow
 $V_{in}=V_{in\ nom}$

Characteristic Curves

All test conditions are at 25°C The figures are identical for MCWI03-24S033

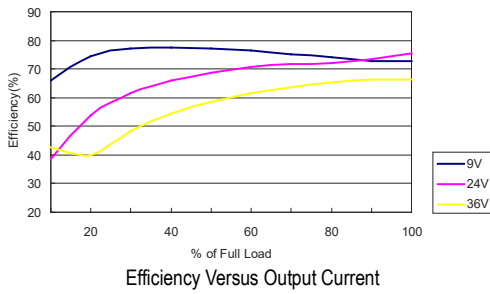

Efficiency Versus Output Current

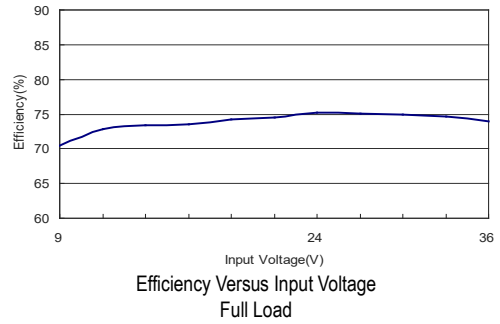

Efficiency Versus Input Voltage Full Load

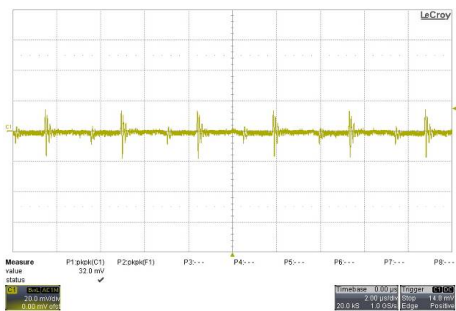

Typical Output Ripple and Noise
 $V_{in}=V_{in\ nom}$; Full Load

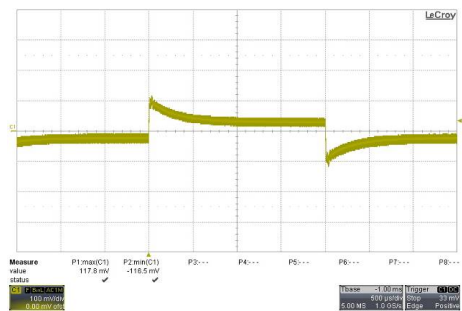

Transient Response to Dynamic Load Change
from 100% to 75% of Full Load ; $V_{in}=V_{in\ nom}$



Typical Input Start-Up and Output Rise Characteristic
 $V_{in}=V_{in\ nom}$; Full Load

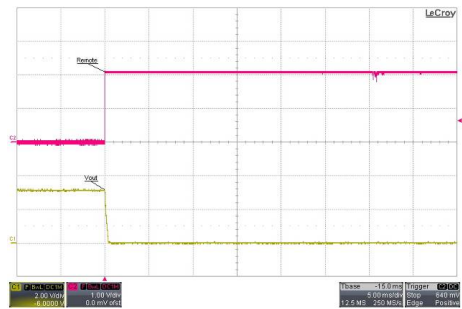

ON/OFF Voltage Start-Up and Output Rise Characteristic
 $V_{in}=V_{in\ nom}$; Full Load

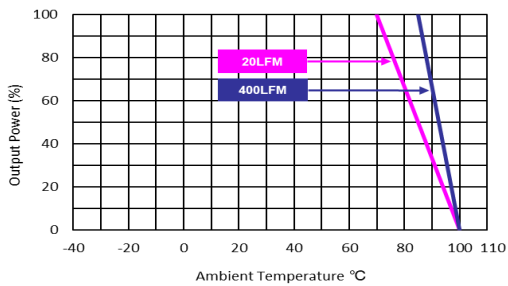

Derating Output Current Versus Ambient Temperature and Airflow
 $V_{in}=V_{in\ nom}$

Characteristic Curves

All test conditions are at 25°C The figures are identical for MCWI03-24S05

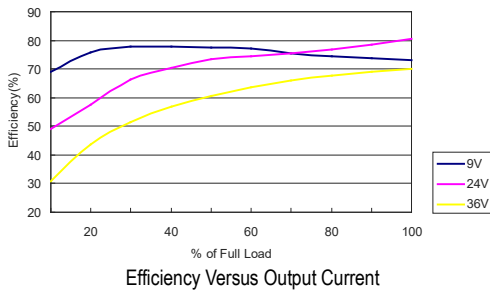

Efficiency Versus Output Current

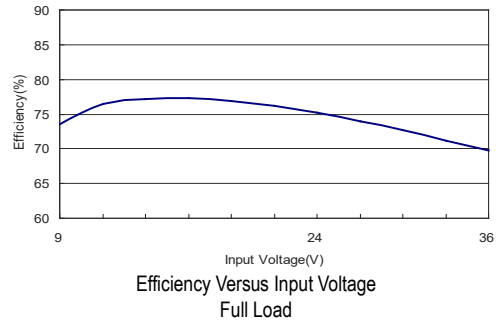

Efficiency Versus Input Voltage Full Load

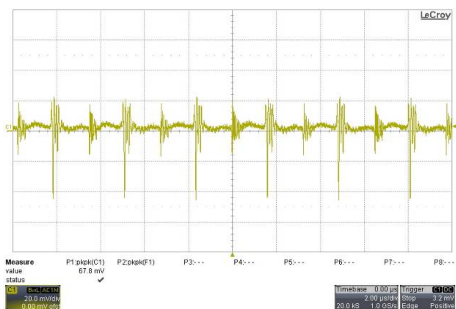

Typical Output Ripple and Noise
 $V_{in}=V_{in\ nom}$; Full Load

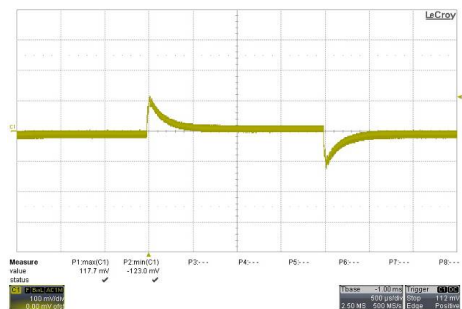

Transient Response to Dynamic Load Change
from 100% to 75% of Full Load ; $V_{in}=V_{in\ nom}$



Typical Input Start-Up and Output Rise Characteristic
 $V_{in}=V_{in\ nom}$; Full Load



ON/OFF Voltage Start-Up and Output Rise Characteristic
 $V_{in}=V_{in\ nom}$; Full Load

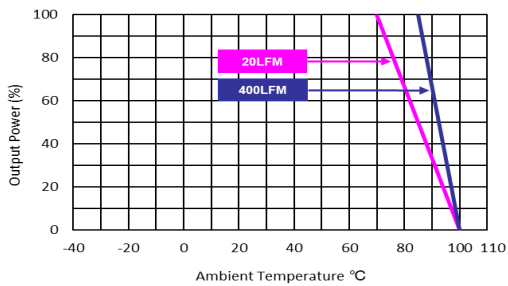

Derating Output Current Versus Ambient Temperature and Airflow
 $V_{in}=V_{in\ nom}$

Characteristic Curves

All test conditions are at 25°C The figures are identical for MCWI03-24S12

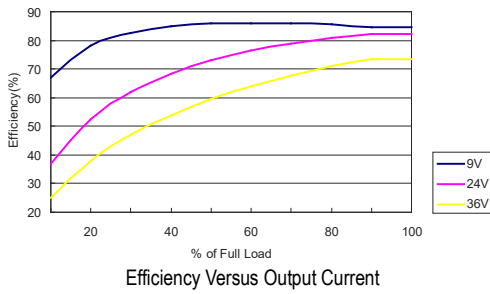

Efficiency Versus Output Current

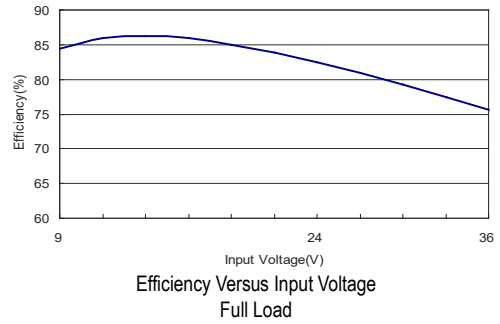

Efficiency Versus Input Voltage Full Load

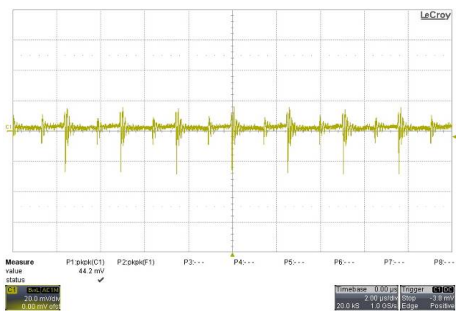

Typical Output Ripple and Noise
 $V_{in}=V_{in\ nom}$; Full Load

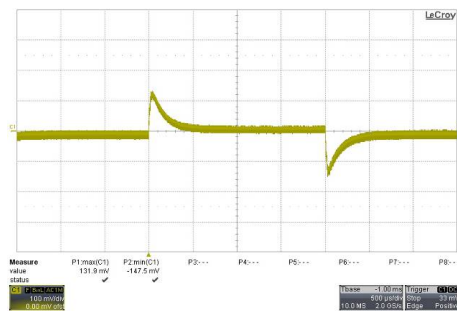

Transient Response to Dynamic Load Change
from 100% to 75% of Full Load ; $V_{in}=V_{in\ nom}$

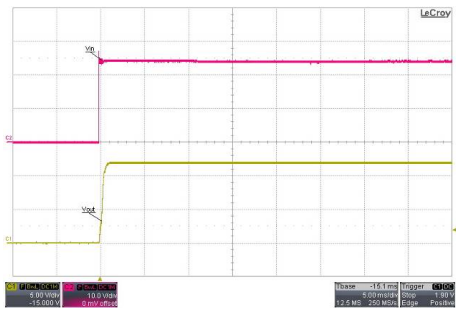

Typical Input Start-Up and Output Rise Characteristic
 $V_{in}=V_{in\ nom}$; Full Load

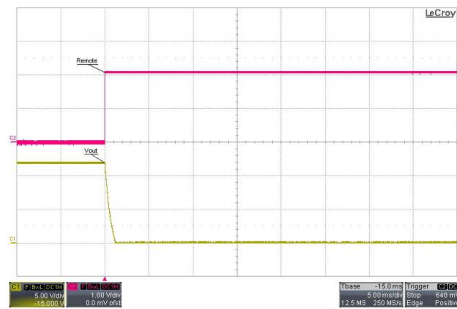

ON/OFF Voltage Start-Up and Output Rise Characteristic
 $V_{in}=V_{in\ nom}$; Full Load

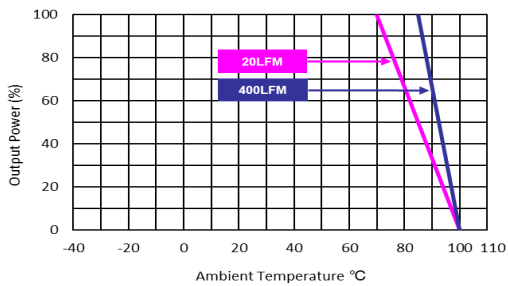

Derating Output Current Versus Ambient Temperature and Airflow
 $V_{in}=V_{in\ nom}$

Characteristic Curves

All test conditions are at 25°C The figures are identical for MCWI03-24S15

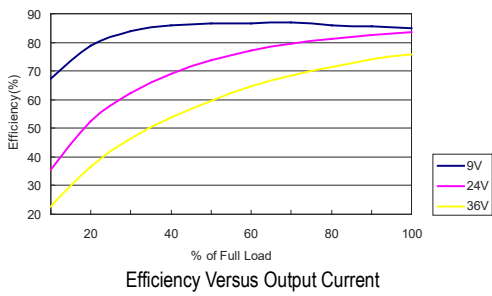

Efficiency Versus Output Current

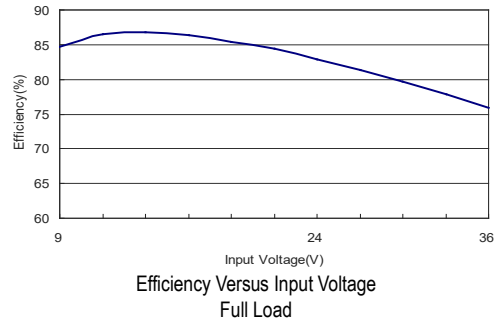

Efficiency Versus Input Voltage Full Load

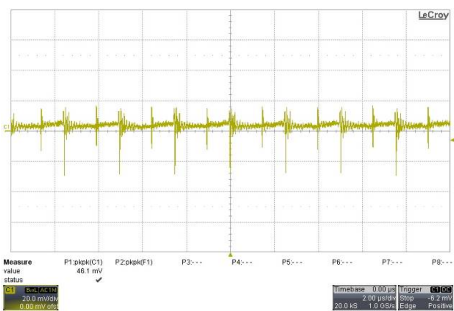

Typical Output Ripple and Noise
 $V_{in}=V_{in\ nom}$; Full Load

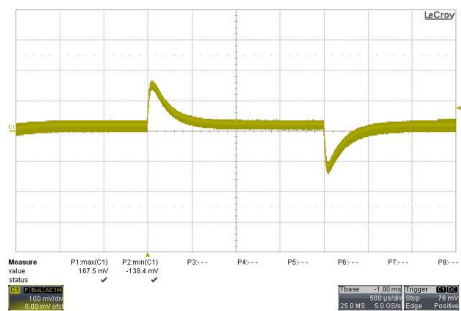

Transient Response to Dynamic Load Change
from 100% to 75% of Full Load ; $V_{in}=V_{in\ nom}$

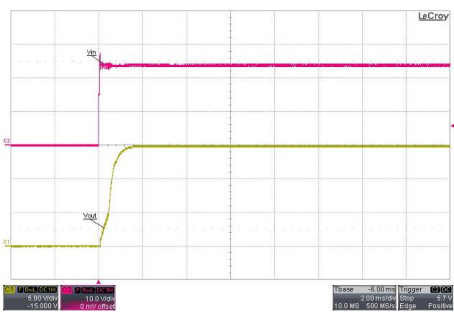

Typical Input Start-Up and Output Rise Characteristic
 $V_{in}=V_{in\ nom}$; Full Load

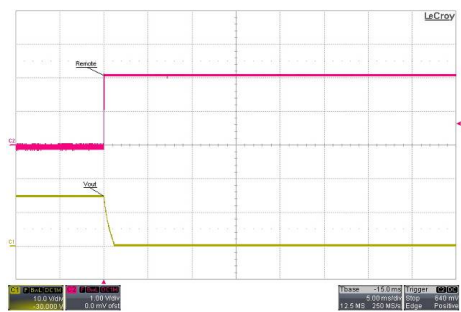

ON/OFF Voltage Start-Up and Output Rise Characteristic
 $V_{in}=V_{in\ nom}$; Full Load

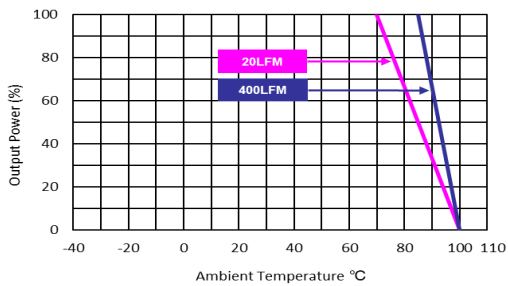

Derating Output Current Versus Ambient Temperature and Airflow
 $V_{in}=V_{in\ nom}$

Characteristic Curves

All test conditions are at 25°C The figures are identical for MCWI03-24D05

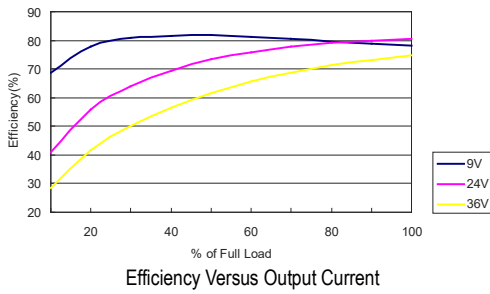

Efficiency Versus Output Current

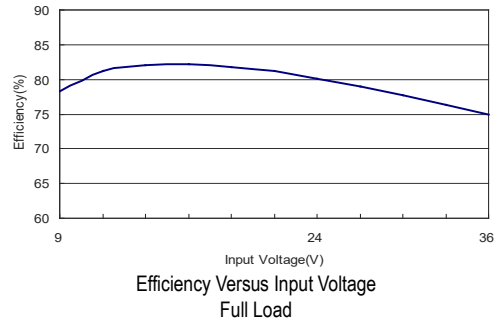

Efficiency Versus Input Voltage Full Load

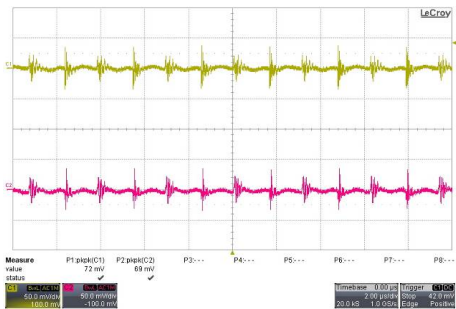

Typical Output Ripple and Noise
 $V_{in}=V_{in\ nom}$; Full Load

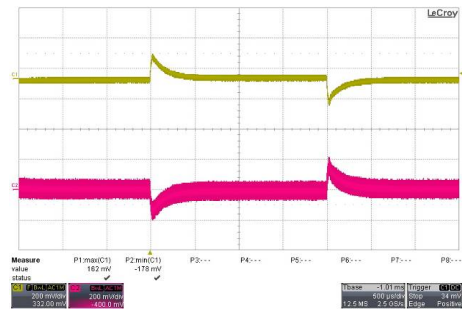

Transient Response to Dynamic Load Change
from 100% to 75% of Full Load ; $V_{in}=V_{in\ nom}$

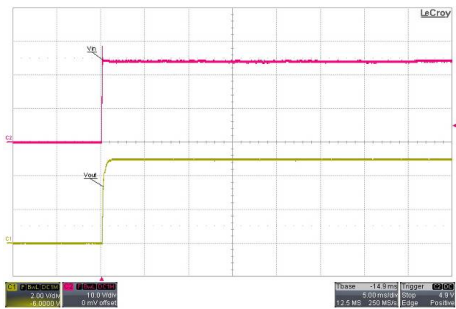

Typical Input Start-Up and Output Rise Characteristic
 $V_{in}=V_{in\ nom}$; Full Load

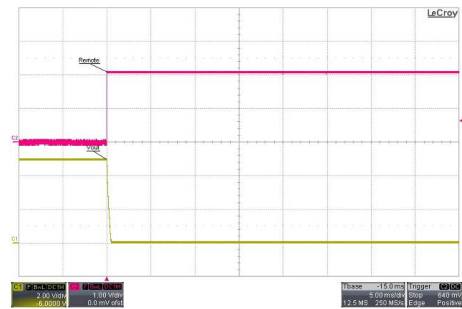

ON/OFF Voltage Start-Up and Output Rise Characteristic
 $V_{in}=V_{in\ nom}$; Full Load

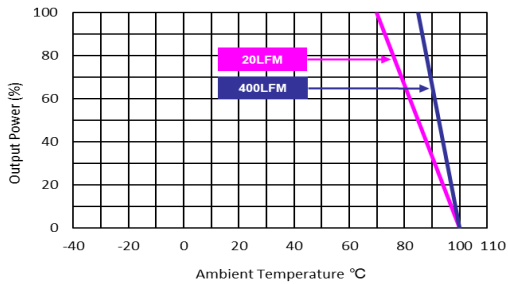

Derating Output Current Versus Ambient Temperature and Airflow
 $V_{in}=V_{in\ nom}$

Characteristic Curves

All test conditions are at 25°C The figures are identical for MCWI03-24D12

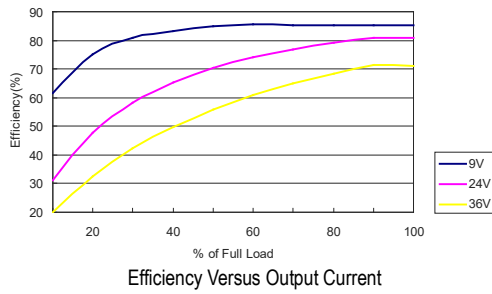

Efficiency Versus Output Current

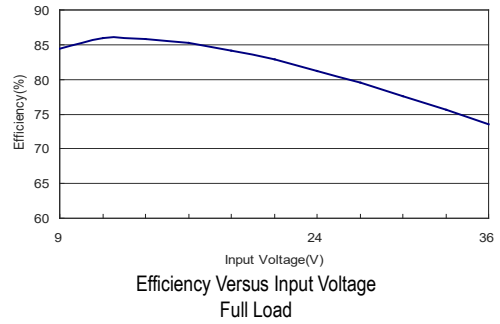

Efficiency Versus Input Voltage Full Load

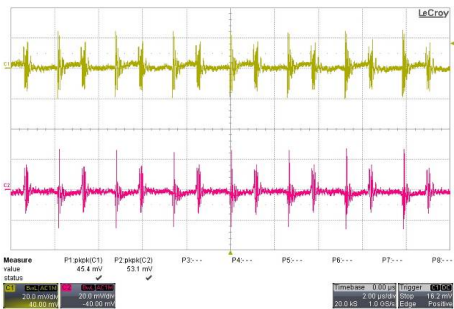

Typical Output Ripple and Noise
 $V_{in}=V_{in\ nom}$; Full Load

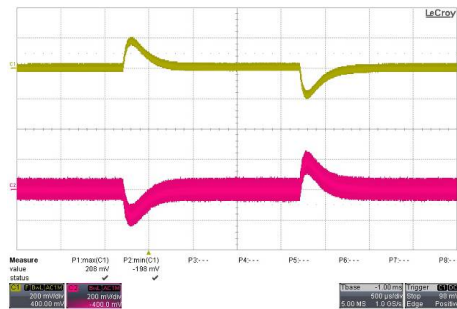

Transient Response to Dynamic Load Change
from 100% to 75% of Full Load ; $V_{in}=V_{in\ nom}$

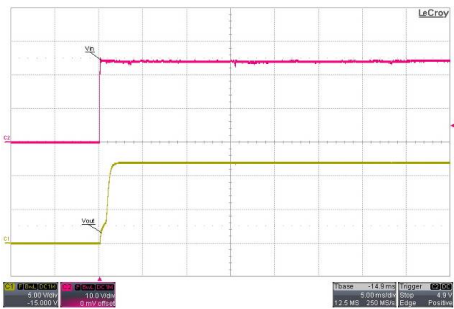

Typical Input Start-Up and Output Rise Characteristic
 $V_{in}=V_{in\ nom}$; Full Load

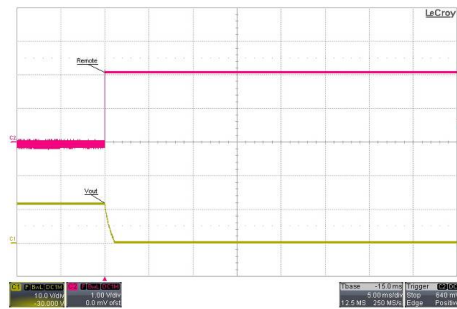

ON/OFF Voltage Start-Up and Output Rise Characteristic
 $V_{in}=V_{in\ nom}$; Full Load

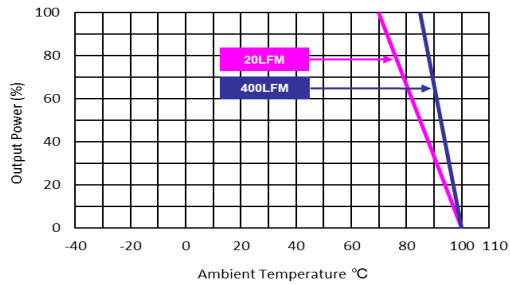

Derating Output Current Versus Ambient Temperature and Airflow
 $V_{in}=V_{in\ nom}$

Characteristic Curves

All test conditions are at 25°C The figures are identical for MCWI03-24D15

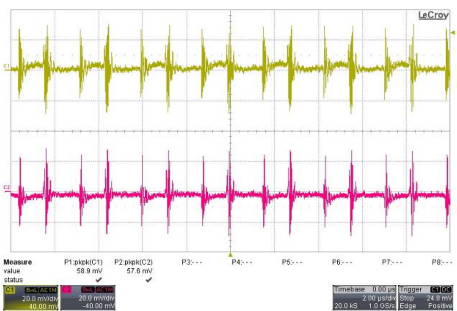
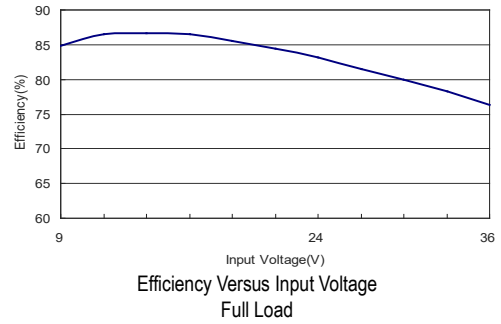
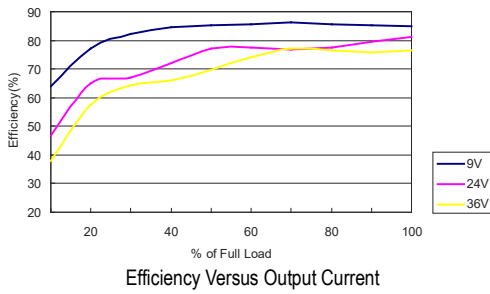

Typical Output Ripple and Noise
 $V_{in}=V_{in\ nom}$; Full Load

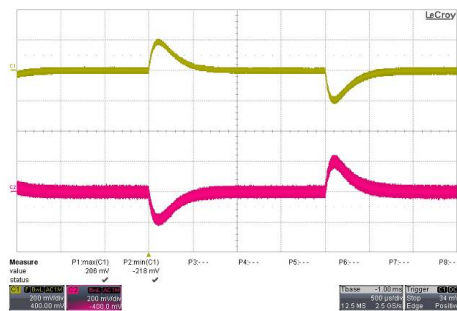

Transient Response to Dynamic Load Change
from 100% to 75% of Full Load ; $V_{in}=V_{in\ nom}$

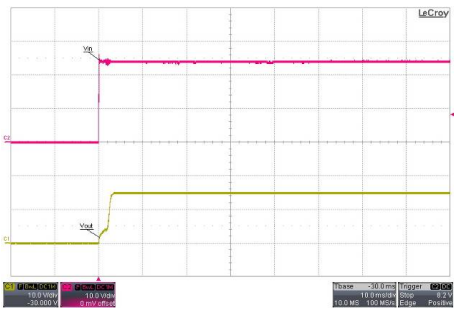

Typical Input Start-Up and Output Rise Characteristic
 $V_{in}=V_{in\ nom}$; Full Load

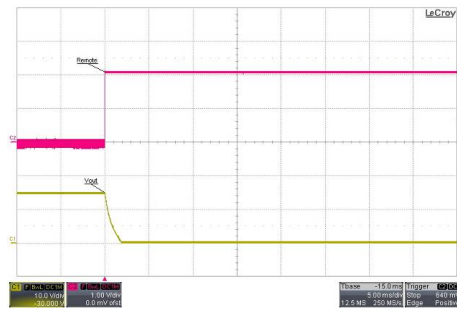

ON/OFF Voltage Start-Up and Output Rise Characteristic
 $V_{in}=V_{in\ nom}$; Full Load

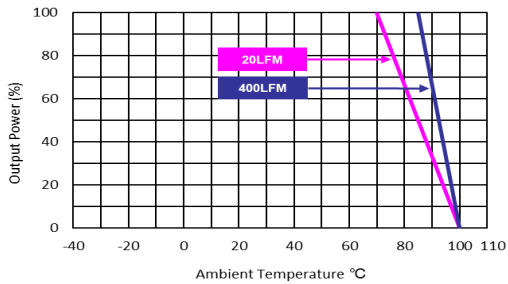

Derating Output Current Versus Ambient Temperature and Airflow
 $V_{in}=V_{in\ nom}$

Characteristic Curves

All test conditions are at 25°C The figures are identical for MCWI03-48S033

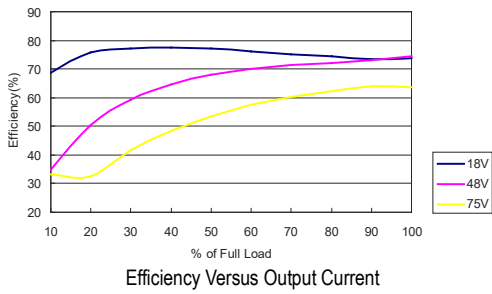

Efficiency Versus Output Current

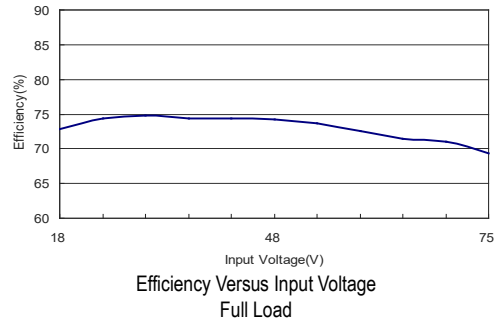

Efficiency Versus Input Voltage Full Load

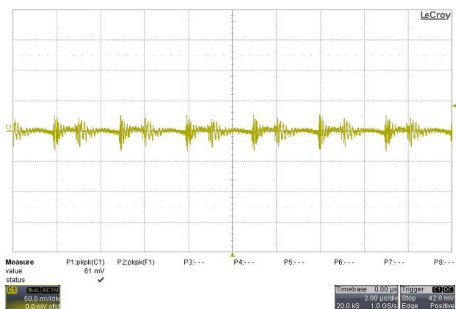

Typical Output Ripple and Noise
 $V_{in}=V_{in\ nom}$; Full Load

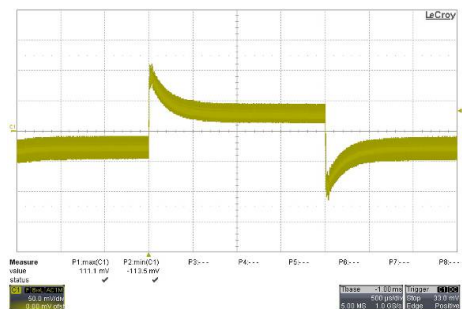

Transient Response to Dynamic Load Change
from 100% to 75% of Full Load ; $V_{in}=V_{in\ nom}$



Typical Input Start-Up and Output Rise Characteristic
 $V_{in}=V_{in\ nom}$; Full Load

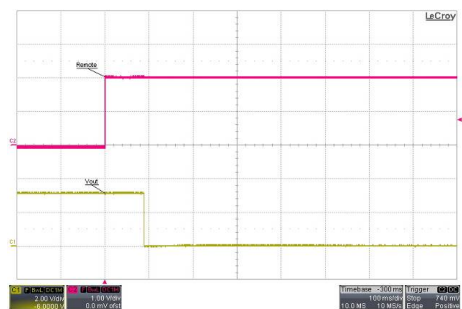

ON/OFF Voltage Start-Up and Output Rise Characteristic
 $V_{in}=V_{in\ nom}$; Full Load

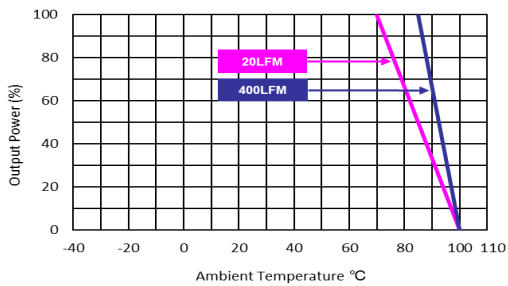

Derating Output Current Versus Ambient Temperature and Airflow
 $V_{in}=V_{in\ nom}$

Characteristic Curves

All test conditions are at 25°C The figures are identical for MCWI03-48S05

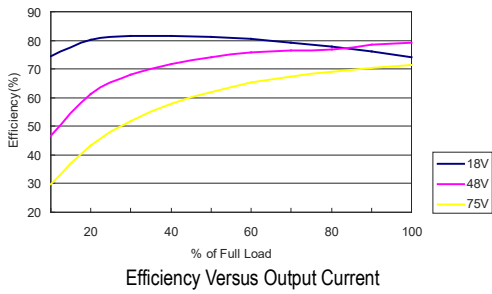

Efficiency Versus Output Current

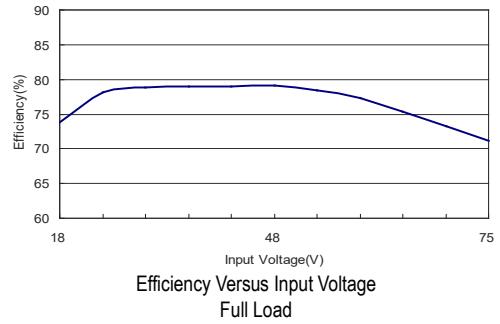

Efficiency Versus Input Voltage Full Load

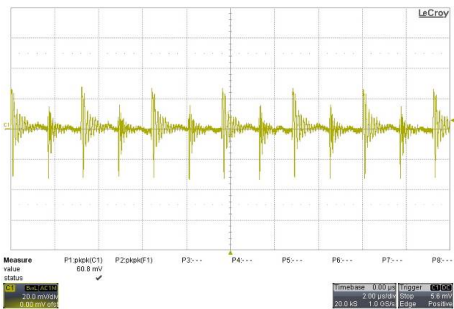

Typical Output Ripple and Noise
 $V_{in}=V_{in\ nom}$; Full Load

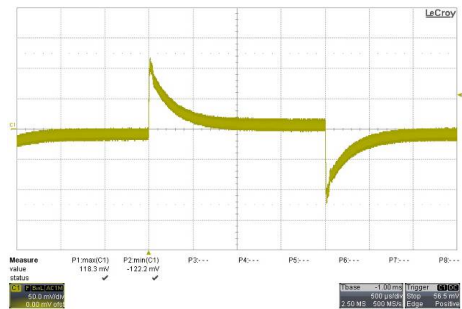

Transient Response to Dynamic Load Change
from 100% to 75% of Full Load ; $V_{in}=V_{in\ nom}$



Typical Input Start-Up and Output Rise Characteristic
 $V_{in}=V_{in\ nom}$; Full Load

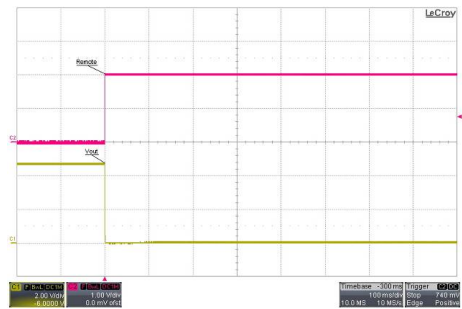

ON/OFF Voltage Start-Up and Output Rise Characteristic
 $V_{in}=V_{in\ nom}$; Full Load

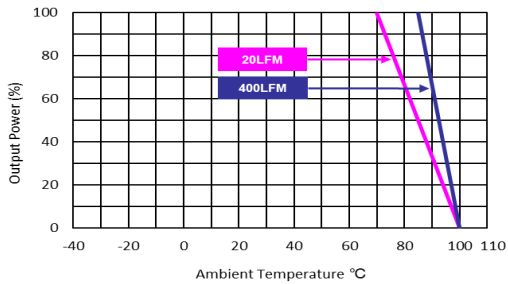

Derating Output Current Versus Ambient Temperature and Airflow
 $V_{in}=V_{in\ nom}$

Characteristic Curves

All test conditions are at 25°C The figures are identical for MCWI03-48S12

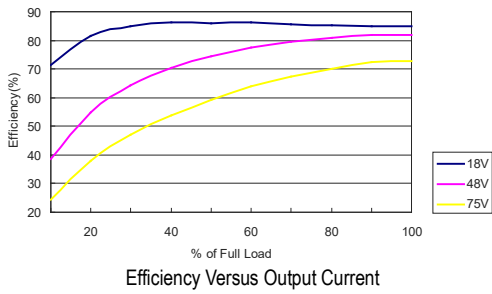

Efficiency Versus Output Current

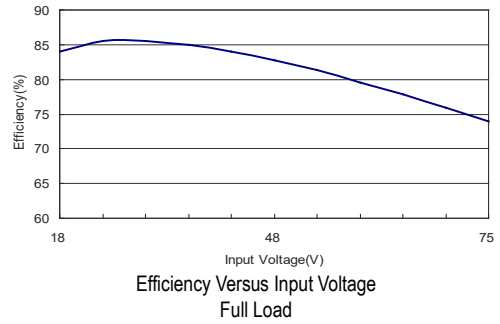

Efficiency Versus Input Voltage Full Load

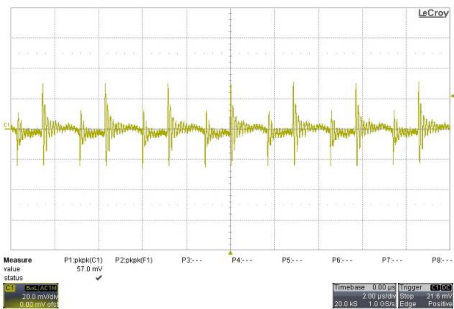

Typical Output Ripple and Noise
 $V_{in}=V_{in\ nom}$; Full Load

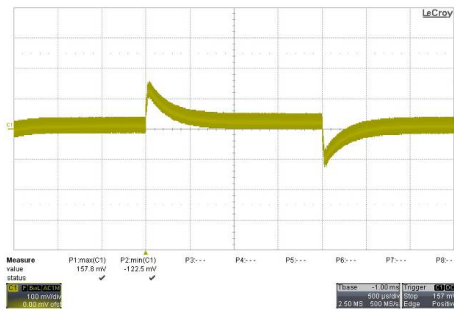

Transient Response to Dynamic Load Change
from 100% to 75% of Full Load ; $V_{in}=V_{in\ nom}$

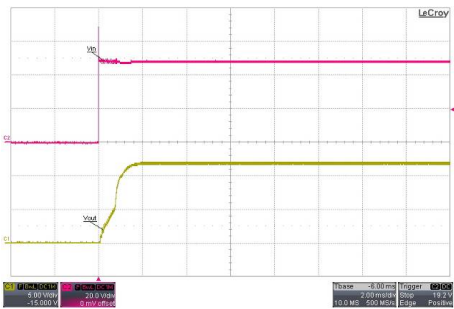

Typical Input Start-Up and Output Rise Characteristic
 $V_{in}=V_{in\ nom}$; Full Load

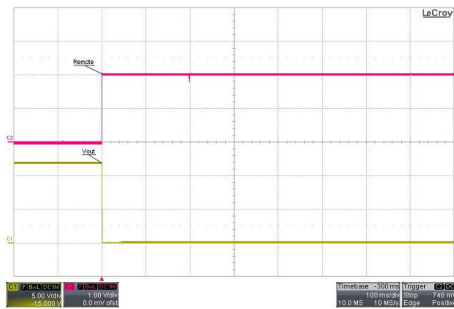

ON/OFF Voltage Start-Up and Output Rise Characteristic
 $V_{in}=V_{in\ nom}$; Full Load

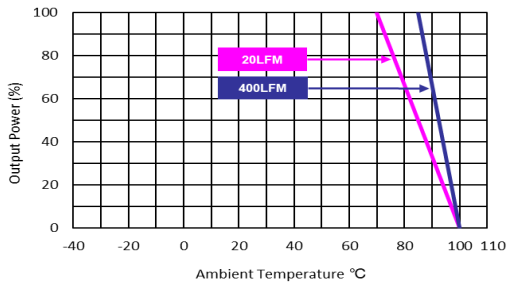

Derating Output Current Versus Ambient Temperature and Airflow
 $V_{in}=V_{in\ nom}$

Characteristic Curves

All test conditions are at 25°C The figures are identical for MCWI03-48S15

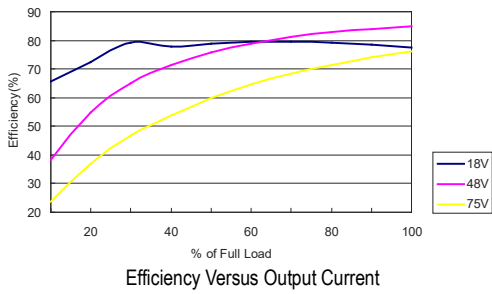

Efficiency Versus Output Current

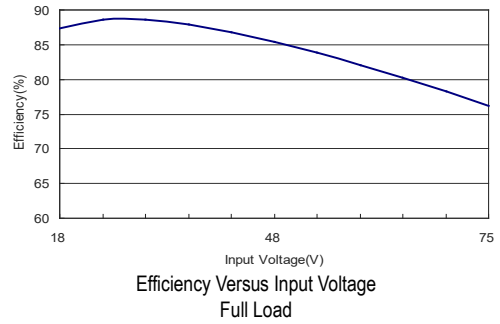

Efficiency Versus Input Voltage Full Load

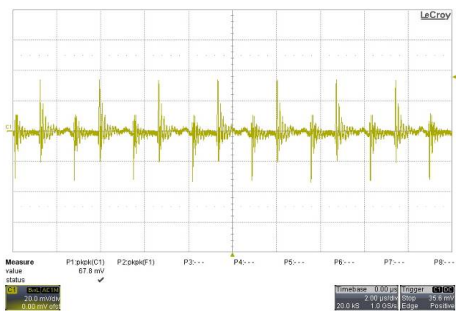

Typical Output Ripple and Noise
 $V_{in}=V_{in\ nom}$; Full Load



Transient Response to Dynamic Load Change
from 100% to 75% of Full Load ; $V_{in}=V_{in\ nom}$

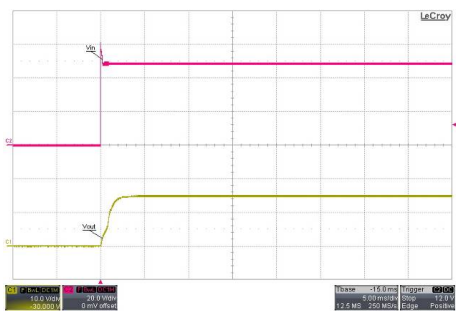

Typical Input Start-Up and Output Rise Characteristic
 $V_{in}=V_{in\ nom}$; Full Load

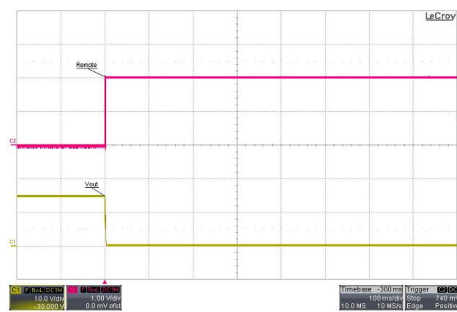

ON/OFF Voltage Start-Up and Output Rise Characteristic
 $V_{in}=V_{in\ nom}$; Full Load

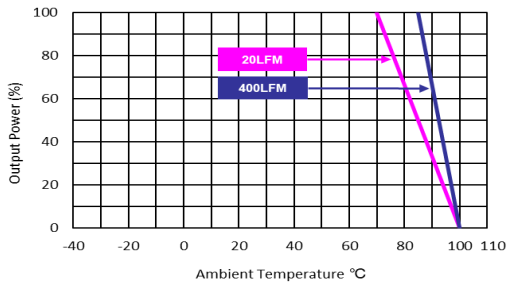

Derating Output Current Versus Ambient Temperature and Airflow
 $V_{in}=V_{in\ nom}$

Characteristic Curves

All test conditions are at 25°C The figures are identical for MCWI03-48D05

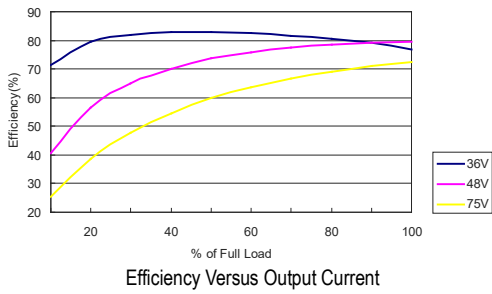

Efficiency Versus Output Current

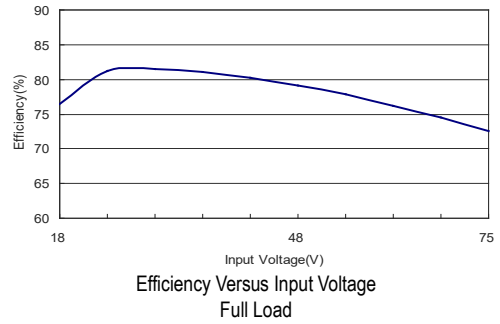

Efficiency Versus Input Voltage Full Load

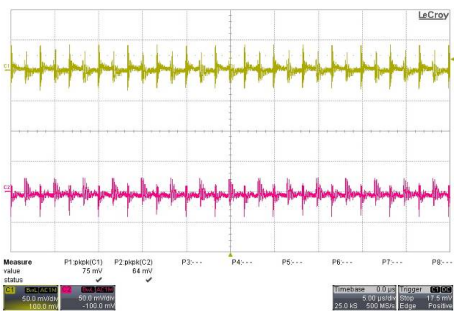

Typical Output Ripple and Noise
 $V_{in}=V_{in\ nom}$; Full Load

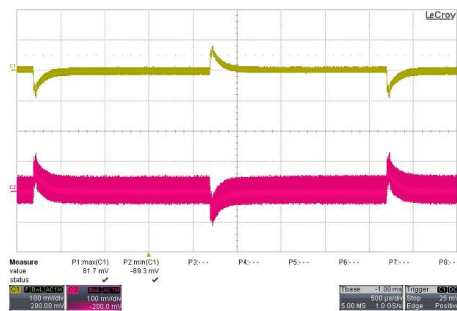

Transient Response to Dynamic Load Change
from 100% to 75% of Full Load ; $V_{in}=V_{in\ nom}$

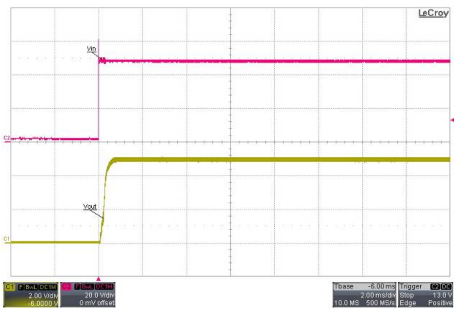

Typical Input Start-Up and Output Rise Characteristic
 $V_{in}=V_{in\ nom}$; Full Load

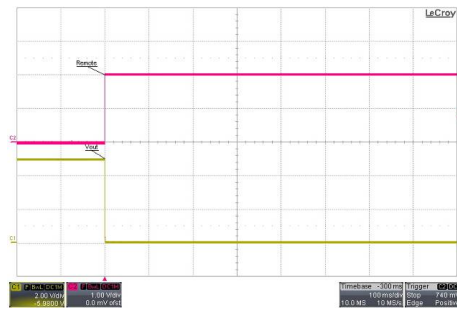

ON/OFF Voltage Start-Up and Output Rise Characteristic
 $V_{in}=V_{in\ nom}$; Full Load

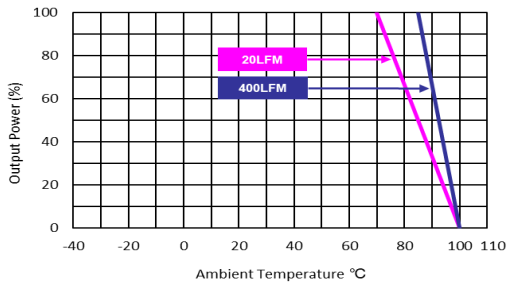

Derating Output Current Versus Ambient Temperature and Airflow
 $V_{in}=V_{in\ nom}$

Characteristic Curves

All test conditions are at 25°C The figures are identical for MCWI03-48D12

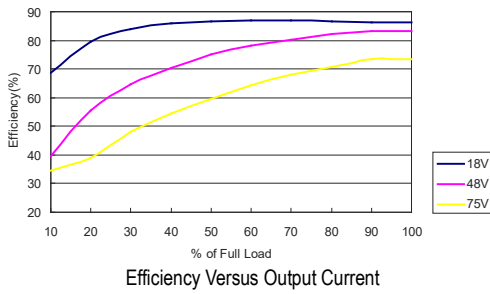

Efficiency Versus Output Current

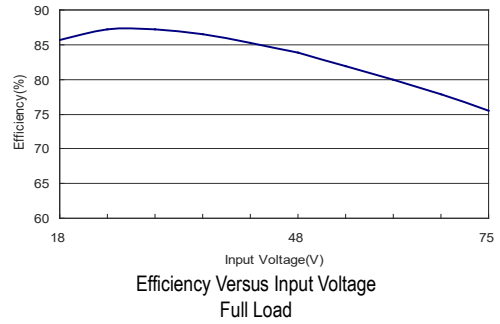

Efficiency Versus Input Voltage Full Load

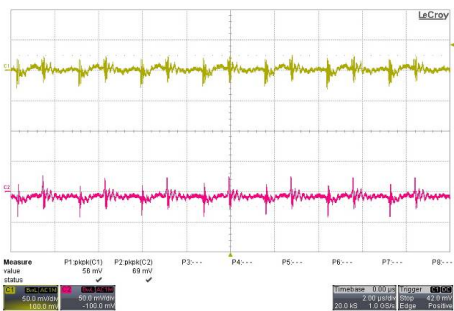

Typical Output Ripple and Noise
 $V_{in}=V_{in\ nom}$; Full Load

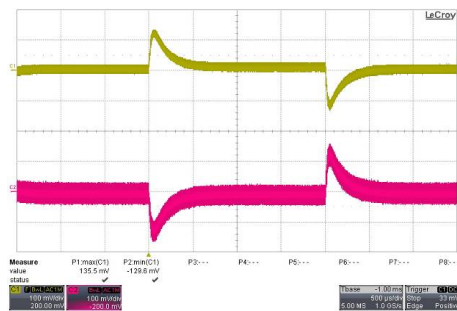

Transient Response to Dynamic Load Change
from 100% to 75% of Full Load ; $V_{in}=V_{in\ nom}$

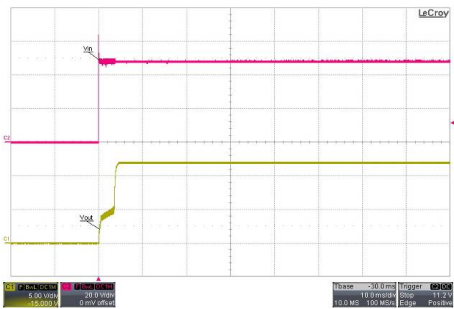

Typical Input Start-Up and Output Rise Characteristic
 $V_{in}=V_{in\ nom}$; Full Load

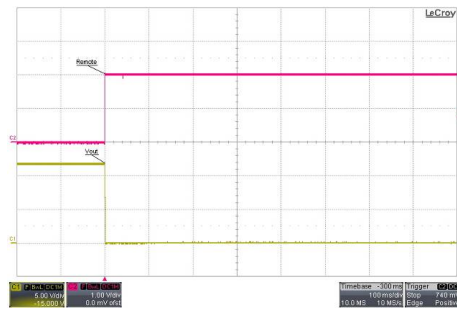

ON/OFF Voltage Start-Up and Output Rise Characteristic
 $V_{in}=V_{in\ nom}$; Full Load

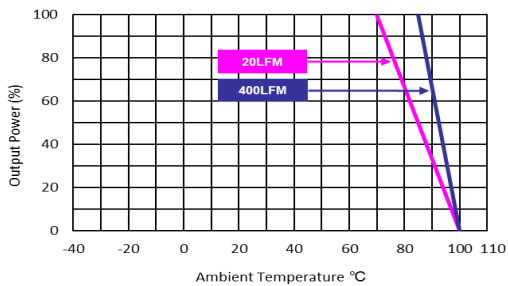

Derating Output Current Versus Ambient Temperature and Airflow
 $V_{in}=V_{in\ nom}$

Characteristic Curves

All test conditions are at 25°C The figures are identical for MCWI03-48D15

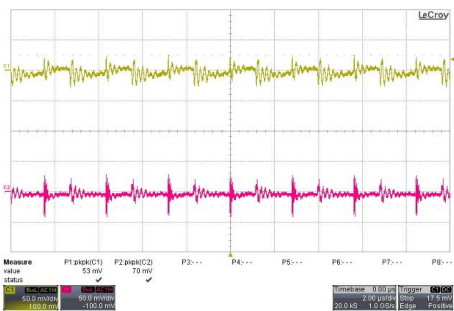
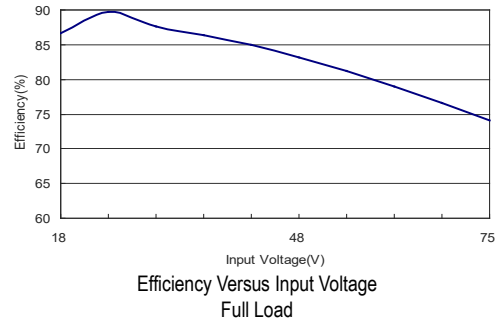
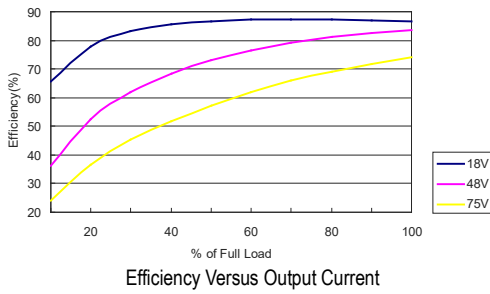

Typical Output Ripple and Noise
 $V_{in}=V_{in\ nom}$; Full Load

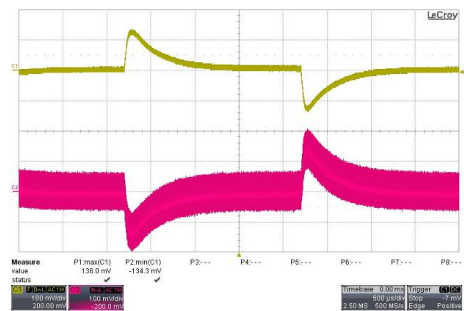

Transient Response to Dynamic Load Change
from 100% to 75% of Full Load ; $V_{in}=V_{in\ nom}$

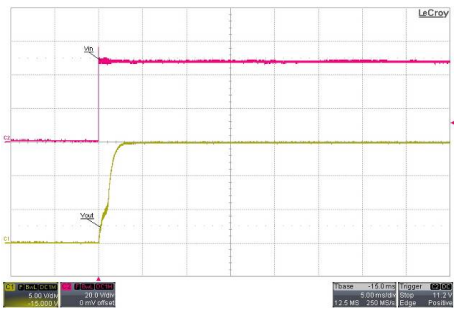

Typical Input Start-Up and Output Rise Characteristic
 $V_{in}=V_{in\ nom}$; Full Load

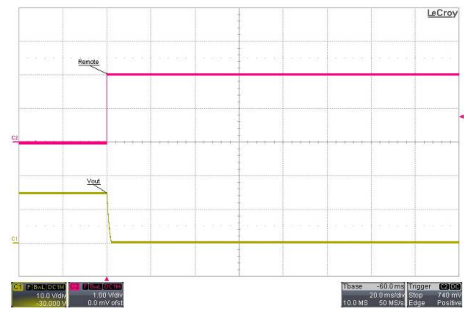

ON/OFF Voltage Start-Up and Output Rise Characteristic
 $V_{in}=V_{in\ nom}$; Full Load

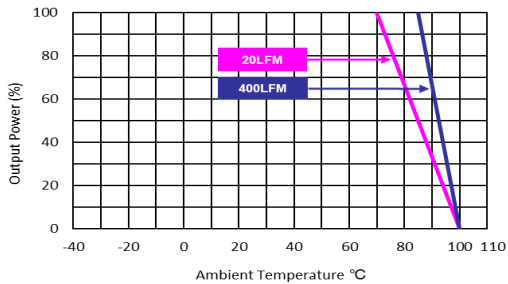

Derating Output Current Versus Ambient Temperature and Airflow
 $V_{in}=V_{in\ nom}$

Package Specifications

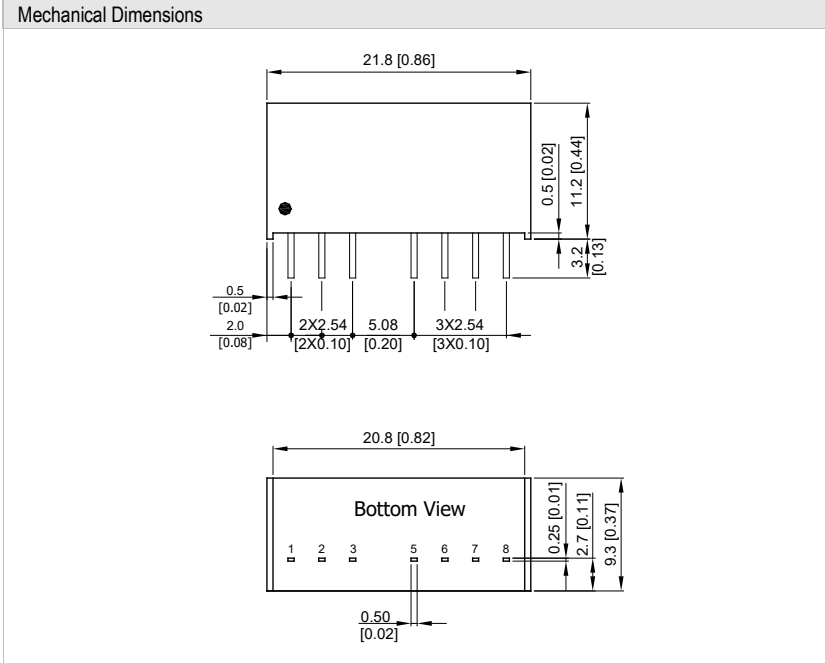

Pin Connections

| Pin | Single Output | Dual Output |
|-----|---------------|---------------|
| 1 | -Vin | -Vin |
| 2 | +Vin | +Vin |
| 3 | Remote On/Off | Remote On/Off |
| 5 | NC | NC |
| 6 | +Vout | +Vout |
| 7 | -Vout | Common |
| 8 | NC | -Vout |

NC: No Connection

- ▶ All dimensions in mm (inches)
- ▶ Tolerance: X.X±0.5 (X.XX±0.02)
X.XX±0.25 (X.XXX±0.01)
- ▶ Pins ±0.1(±0.004)

Physical Characteristics

| | |
|---------------|-----------------------------------------------------------------|
| Case Size | : 21.8x9.3x11.2 mm (0.86x0.37x0.44 inches) |
| Case Material | : Non-Conductive Black Plastic (flammability to UL 94V-0 rated) |
| Pin Material | : Alloy 42 |
| Weight | : 4.8g |

Recommended Pad Layout for Single & Dual Output Converter

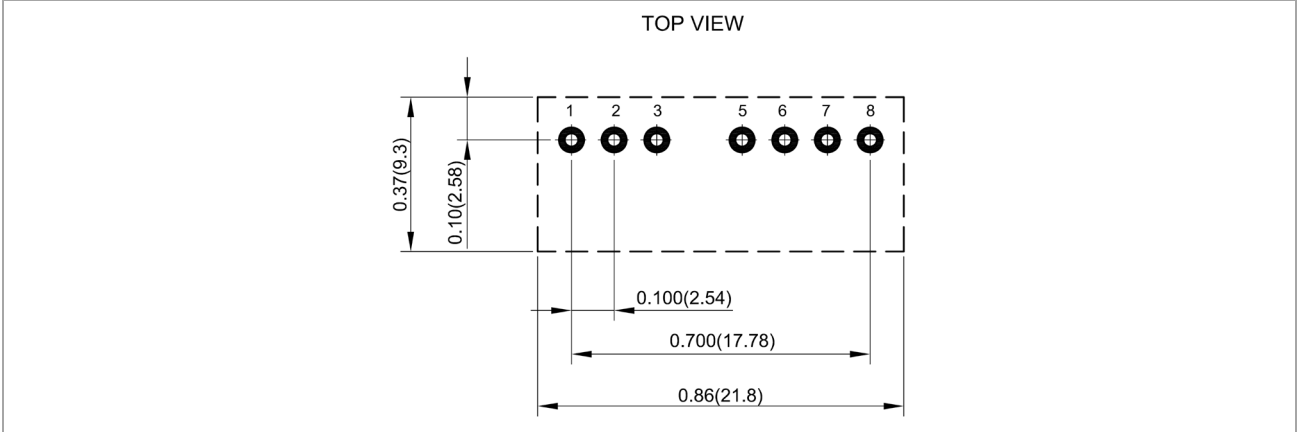

Test Setup

Peak-to-Peak Output Noise Measurement Test

Use a C_{out} 0.47 μ F ceramic capacitor. Scope measurement should be made by using a BNC socket, measurement bandwidth is 0-20 MHz. Position the load between 50 mm and 75 mm from the DC-DC Converter.

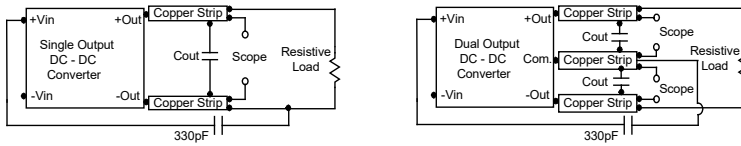

Technical Notes

Remote On/Off

Negative logic remote on/off turns the module off during a logic high voltage on the remote on/off pin, and on during a logic low. To turn the power module on and off, the user must supply a switch to control the voltage between the on/off terminal and the -Vin terminal. The switch can be an open collector or equivalent. A logic high is 2.7V to 15V. A logic low is under 0.6 VDC or open circuit, drops down to 0VDC by 2mV/°C. The maximum sink current at on/off terminal during a logic low is 1 mA. The maximum allowable leakage current of the switch at on/off terminal= (under 0.6VDC or open circuit) is 1mA.

Maximum Capacitive Load

The MCWI03 series has limitation of maximum connected capacitance at the output. The power module may be operated in current limiting mode during start-up, affecting the ramp-up and the startup time. The maximum capacitance can be found in the data sheet.

Overcurrent Protection

To provide protection in a fault (output overload) condition, the unit is equipped with internal current limiting circuitry and can endure current limiting for an unlimited duration. At the point of current-limit inception, the unit shifts from voltage control to current control. The unit operates normally once the output current is brought back into its specified range.

Input Source Impedance

The power module should be connected to a low ac-impedance input source. Highly inductive source impedances can affect the stability of the power module. In applications where power is supplied over long lines and output loading is high, it may be necessary to use a capacitor at the input to ensure startup. Capacitor mounted close to the power module helps ensure stability of the unit, it is commended to use a good quality low Equivalent Series Resistance (ESR < 1.0 Ω at 100 kHz) capacitor of a 3.3 μ F for the 12V input devices and a 1.5 μ F for the 24V and 48V devices.

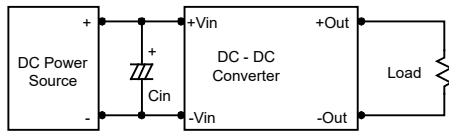

Output Ripple Reduction

A good quality low ESR capacitor placed as close as practicable across the load will give the best ripple and noise performance. To reduce output ripple, it is recommended to use 3.3 μ F capacitors at the output.

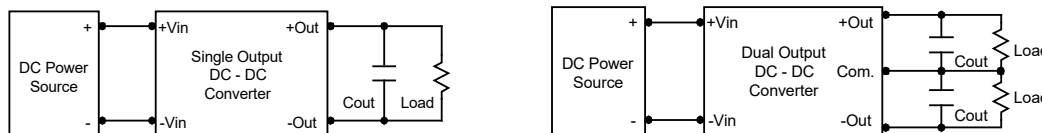

Thermal Considerations

Many conditions affect the thermal performance of the power module, such as orientation, airflow over the module and board spacing. To avoid exceeding the maximum temperature rating of the components inside the power module, the case temperature must be kept below 105°C. The derating curves are determined from measurements obtained in a test setup.

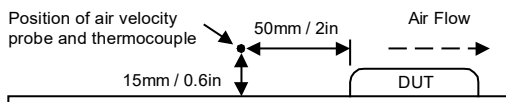

Remote ON/OFF Implementation

The negative logic remote ON/OFF control circuit is included. Turns the module OFF during logic High on the ON/OFF pin and turns ON during logic Low. The ON/OFF input signal ($V_{on/off}$) that referenced to GND. If not using the remote on/off feature, please open circuit between on/off pin and -Vin pin to turn the module on.

Remote ON/OFF implementation

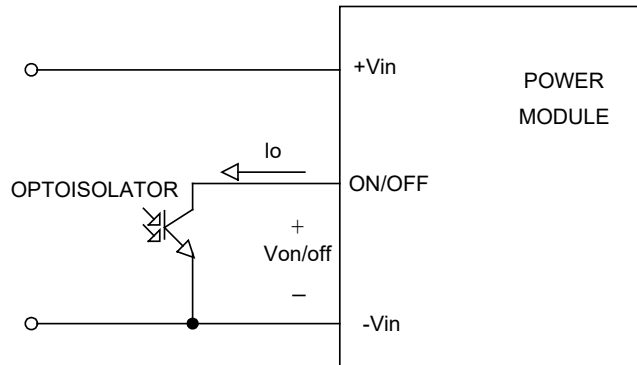

Isolated-Closure Remote ON/OFF

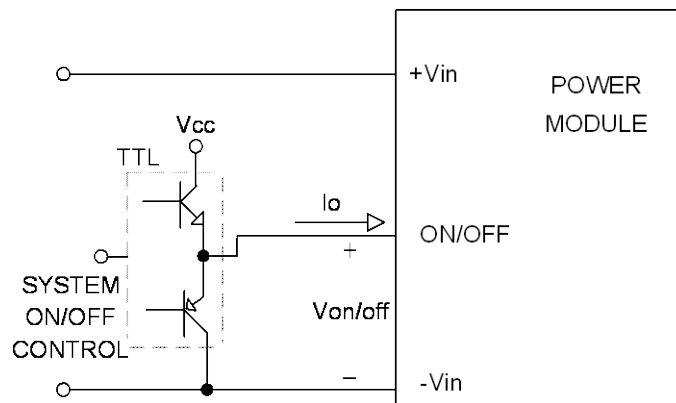

Level Control Using TTL Output

Packaging Information

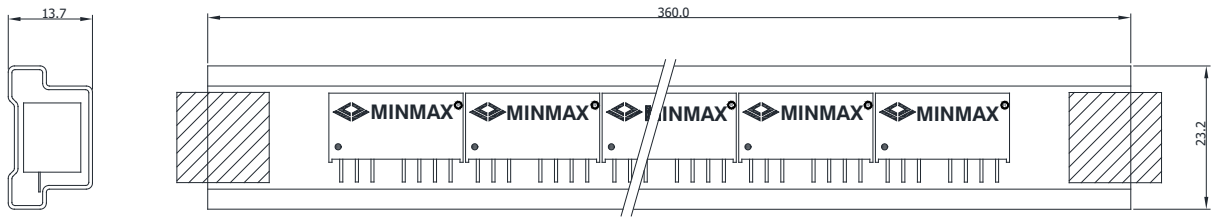

Unit: mm
10 PCS per TUBE

Wave Soldering Considerations

Lead free wave solder profile

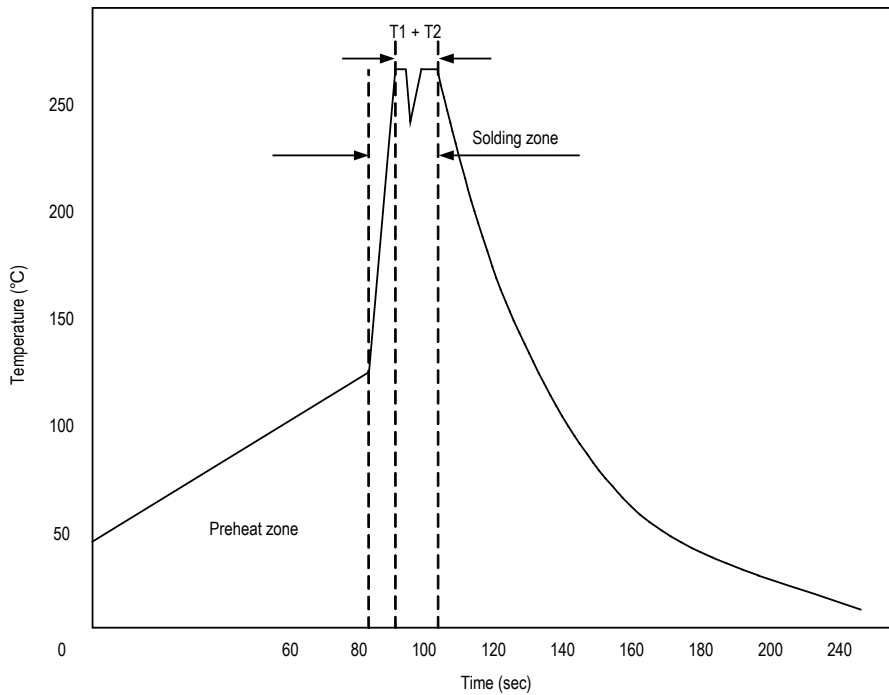

| Zone | Reference Parameter |
|---------|---------------------------------|
| Preheat | Rise temp. speed : 3°C/sec max. |
| zone | Preheat temp. : 100~130°C |
| Actual | Peak temp. : 250~260°C |
| heating | Peak time(T1+T2) : 4~6 sec |

Hand Welding Parameter

Reference Solder: Sn-Ag-Cu : Sn-Cu : Sn-Ag

Hand Welding: Soldering iron : Power 60W

Welding Time: 2~4 sec

Temp.: 380~400°C

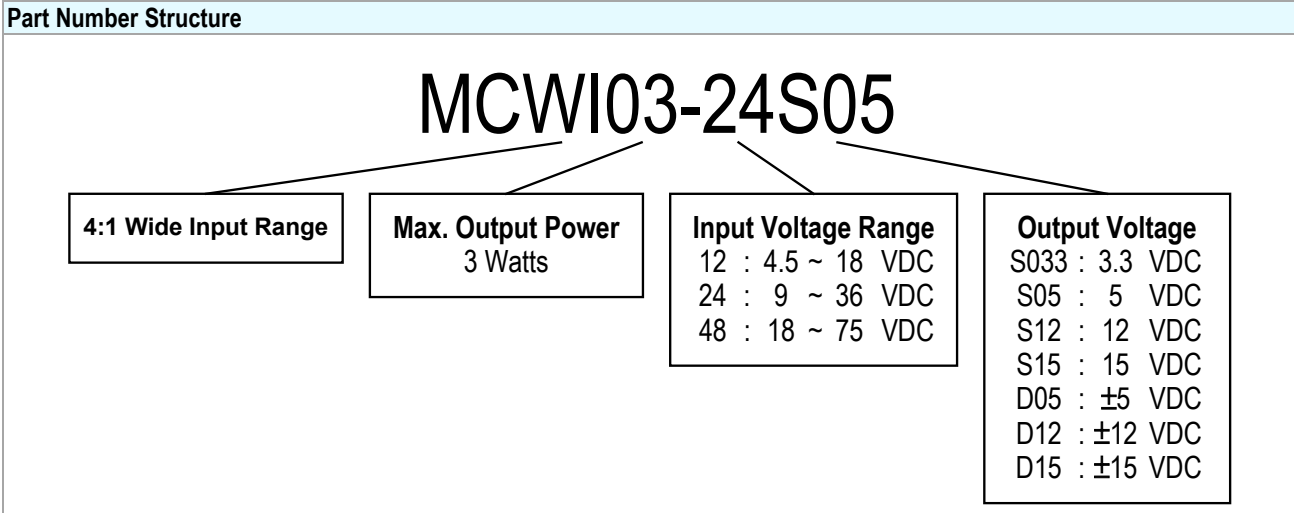

MTBF and Reliability

The MTBF of MCWI03 series of DC-DC converters has been calculated using

MIL-HDBK 217F NOTICE2, Operating Temperature 25°C, Ground Benign.

| Model | MTBF | Unit |
|---------------|-----------|-------|
| MCWI03-12S033 | 897,989 | Hours |
| MCWI03-12S05 | 1,018,123 | |
| MCWI03-12S12 | 1,102,901 | |
| MCWI03-12S15 | 1,104,362 | |
| MCWI03-12D05 | 947,418 | |
| MCWI03-12D12 | 1,015,641 | |
| MCWI03-12D15 | 1,026,694 | |
| MCWI03-24S033 | 944,555 | |
| MCWI03-24S05 | 1,043,950 | |
| MCWI03-24S12 | 1,120,951 | |
| MCWI03-24S15 | 1,120,951 | |
| MCWI03-24D05 | 962,464 | |
| MCWI03-24D12 | 1,061,797 | |
| MCWI03-24D15 | 1,041,884 | |
| MCWI03-48S033 | 959,509 | |
| MCWI03-48S05 | 1,035,197 | |
| MCWI03-48S12 | 1,128,668 | |
| MCWI03-48S15 | 1,150,219 | |
| MCWI03-48D05 | 953,380 | |
| MCWI03-48D12 | 977,135 | |
| MCWI03-48D15 | 1,036,269 | |