



MINMAX[®]

AMF-30 Series

Electric Characteristic Note

AMF-30 Series EC Note

AC-DC POWER MODULE 30W

Features

- ▶ Ultra Compact Size 2.52x1.77x0.94 "
- ▶ Fully Encapsulated Plastic Case for PCB, Chassis and DIN-Rail Mounting Version
- ▶ Universal Input 85-264VAC, 90-370VDC, 47-440Hz
- ▶ I/O Isolation 3000VAC with Reinforced Insulation
- ▶ No Min. Load Requirement & Low no-load power consumption
- ▶ Operating Ambient Temp. Range -40°C to +70°C
- ▶ Overload/Voltage and Short Circuit Protection
- ▶ EMI Emission EN55014-1/55032 Class B Approved
- ▶ EMS Immunity EN61000-4-2,3,4,5,6,8,11 Approved
- ▶ Safety Approval to UL/cUL/IEC/EN 62368-1, IEC/EN 60335-1 & CE Marking



Applications

- ▶ Distributed power architectures
- ▶ Workstations
- ▶ Computer equipment
- ▶ Communications equipment

Product Overview

The MINMAX AMF-30 series is a new generation of fully encapsulated AC-DC power supply modules with ultra-compact size for higher power density and space saving.

The product features universal AC input 85-264VAC and wider DC input 90-370VDC, regulated output voltages 5.1, 12, 15, 24, 48VDC ; I/O Isolation 3000VAC with Reinforced Insulation ; EMI emission EN55014-1/32 Class B and EMS immunity EN 61000-4 standards approved ; no min. load requirement and low no-load power consumption; abnormal protection mechanism with output overload, short circuit and overvoltage protections.

The AMF-30 series equips with PCB, Chassis and DIN-Rail Mounting Version for flexible installation and comply with UL/IEC/EN 62368-1 & IEC/EN 60335-1 for safety usage. It provides a cost effective solution especially for space critical applications in industrial and household electronic equipment.

Table of contents

Model Selection Guide	P2	Screw terminal with DIN Rail Mounting	P10
Input Specifications	P2	Package Specifications Chassis Mounting with JST connection	P11
Output Specifications	P2	Package Specifications for JST connection with DIN Rail Mounting	P11
General Specifications	P2	JST connection with DIN Rail Mounting	P11
EMC Specifications	P3	Recommended Pad Layout	P12
Environmental Specifications	P3	Packaging Information	P12
Characteristic Curves	P4	Wave Soldering Considerations	P13
Package Specifications PCB Mounting	P9	Hand Welding Parameter	P13
Package Specifications Chassis Mounting with screw terminal	P9	Part Number Structure	P14
Package Specifications for screw terminal with DIN Rail Mounting	P10	MTBF and Reliability	P14

Model Selection Guide

Model Number	Output Voltage	Output Power	Output Current	Input Current	Max. capacitive Load	Efficiency (typ.)
			Max.	115VAC, 60Hz @Max. Load		@Max. Load
	VDC	W	A	mA(typ.)	μF	%
AMF-30S051	5.1	25.5	5	486	6800	86
AMF-30S12	12	30	2.5	570	1200	88
AMF-30S15	15	30	2	570	680	88
AMF-30S24	24	30	1.25	570	560	88
AMF-30S48	48	30	0.625	570	100	88

Input Specifications

Parameter	Conditions / Model		Min.	Typ.	Max.	Unit
AC Input Voltage Range	All Models		85	---	264	VAC
AC Input Frequency Range			47	---	440	Hz
DC Input Voltage Range			90	---	370	VDC
No-Load Power Consumption	115VAC	PCB Mounting	---	---	100	mW
	230VAC		---	---	200	mW
	115VAC	Chassis Mounting	---	---	150	mW
	230VAC		---	---	250	mW
Inrush Current	115VAC	Cold Start at 25°C	---	---	30	A
	230VAC		---	---	60	A

Output Specifications

Parameter	Conditions / Model		Min.	Typ.	Max.	Unit
Output Voltage Accuracy			---	±1.0	±2.0	%
Line Regulation	Vin=Min. to Max. @Full Load		---	---	±0.5	%
Load Regulation	Io=0% to 100%		---	---	±1.0	%
Ripple & Noise	0-20 MHz Bandwidth	5.1VDC Output Model	---	---	1.8	%V _{PP} of Vo
		Other Output Models	---	---	1.0	%V _{PP} of Vo
Minimum Load	No minimum Load Requirement					
Over Voltage Protection	Zener diode clamp		---	125	---	% of Vo
Temperature Coefficient			---	±0.01	±0.02	%/°C
Overshoot			---	---	5	% Vout
Over Load Protection	auto-recovery		110	---	---	%Inom.
	(long term overload condition may cause damage)					
Short Circuit Protection	Hiccup mode, Automatic Recovery					

General Specifications

Parameter	Conditions	Min.	Typ.	Max.	Unit
I/O Isolation Voltage	Input to Output, 60 Seconds	3000	---	---	VAC
I/O Isolation Resistance	500 VDC	10	---	---	GΩ
Switching Frequency		---	65	---	kHz
Start-up Time		---	---	1	s
Hold-up Time	115VAC, 60Hz	10	---	---	ms
	230VAC, 50Hz	20	---	---	ms
MTBF (calculated)	MIL-HDBK-217F@25°C, Ground Benign	414,725	---	---	Hours
Safety Approvals	UL/cUL 62368-1 recognition(UL certificate), IEC/EN 62368-1(CB-report)				
	IEC/EN 60335-1, 61558-1, 61558-2-16 recognition(CB-report)				

EMC Specifications				
Parameter	Standards & Level			Performance
General	Compliance with EN 61204-3 Switch mode power supplies			
EMI	Conduction	EN 55014-1, EN 55032	Without external components	Class B
	Radiation			
EMS	EN 55014-2, EN 55035			
	ESD	Direct discharge	Indirect discharge HCP & VCP	
		EN61000-4-2 air ± 8kV	Contact ± 6kV	
	Radiated immunity	EN 61000-4-3 10V/m		
	Fast transient	EN 61000-4-4 ±2kV		
	Surge	EN 61000-4-5 ±1kV		
	Conducted immunity	EN 61000-4-6 10Vrms		
	PFMF	EN 61000-4-8 30A/m		
	Dips	EN 61000-4-11 30% 10ms		
Interruptions	EN 61000-4-11 >95% 5000ms			

Environmental Specifications					
Parameter	Min.	Typ.	Max.	Unit	
Operating Ambient Temperature Range (See Power Derating Curve)	-40	---	+70	°C	
Storage Temperature Range	-40	---	+85	°C	
Humidity (non condensing)	---	---	95	% rel. H	
Lead Temperature (1.5mm from case for 10Sec.)	---	---	260	°C	

Notes	
1	All Specifications typical at Ta=+25°C, resistive load, 115VAC, 60Hz input voltage and after warm-up time rated output current unless otherwise noted.
2	We recommend to protect the converter by a slow blow fuse in the input supply line.
3	Other input and output voltage may be available, please contact MINMAX.
4	Specifications are subject to change without notice
5	The repeated high voltage isolation testing of the converter can degrade isolation capability, to a lesser or greater degree depending on materials, construction, environment and reflow solder process. Any material is susceptible to eventual chemical degradation when subject to very high applied voltages thus implying that the number of tests should be strictly limited. We therefore strongly advise against repeated high voltage isolation testing, but if it is absolutely required, that the voltage be reduced by 20% from specified test voltage. Furthermore, the high voltage isolation capability after reflow solder process should be evaluated as it is applied on system.

Characteristic Curves

All test conditions are at 25°C The figures are identical for AMF-30S051

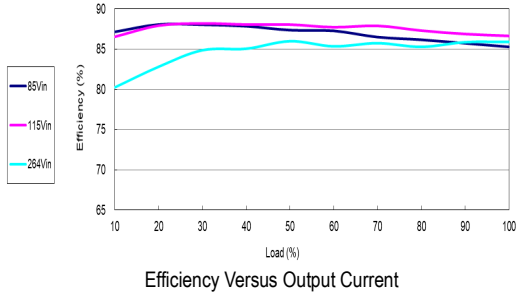

Efficiency Versus Output Current

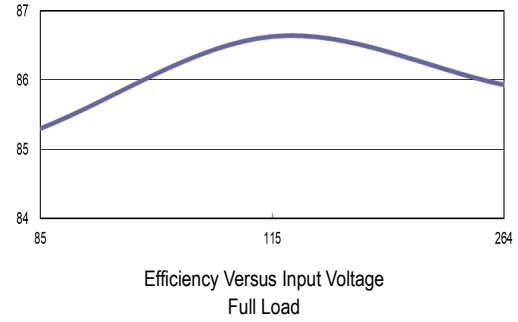

Efficiency Versus Input Voltage Full Load

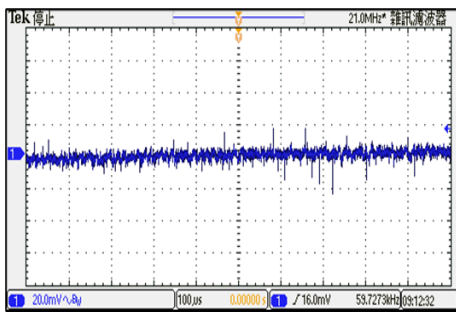

Typical Output Ripple and Noise
 $V_{in}=V_{in\ nom}$; Full Load

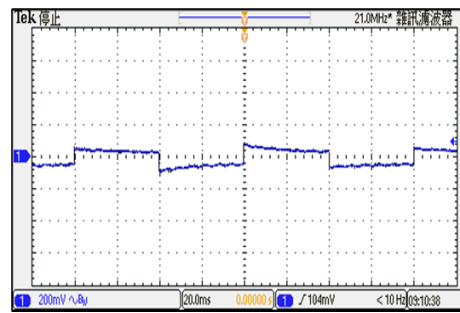

Transient Response to Dynamic Load Change
from 100% to 75% of Full Load ; $V_{in}=V_{in\ nom}$

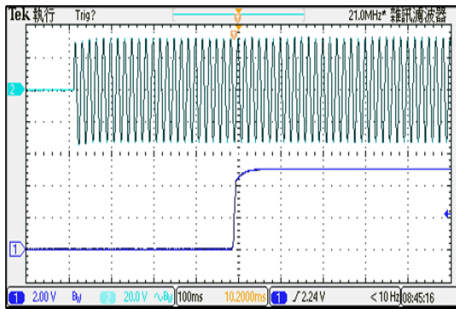

Typical Input Start-Up and Output Rise Characteristic
 $V_{in}=V_{in\ nom}$; Full Load

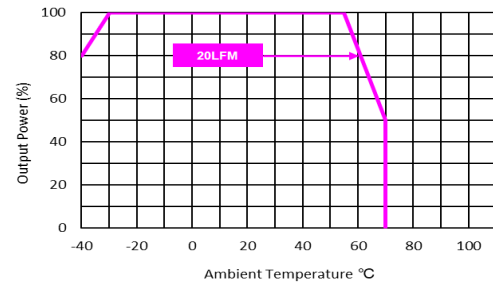

Derating Output Current Versus Ambient Temperature
 $V_{in}=V_{in\ nom}$

Characteristic Curves

All test conditions are at 25°C The figures are identical for AMF-30S12

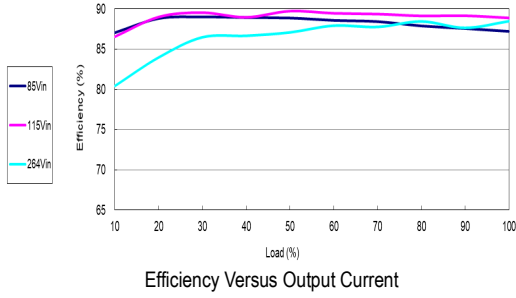

Efficiency Versus Output Current

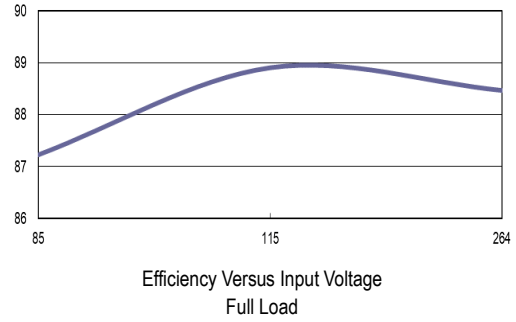

Efficiency Versus Input Voltage Full Load

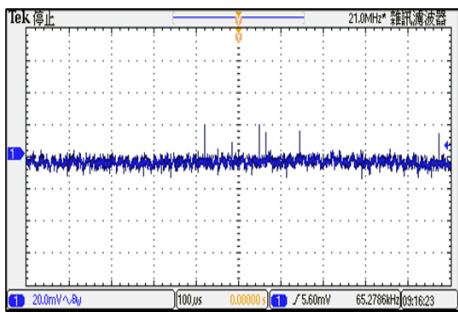

Typical Output Ripple and Noise
 $V_{in}=V_{in\ nom}$; Full Load

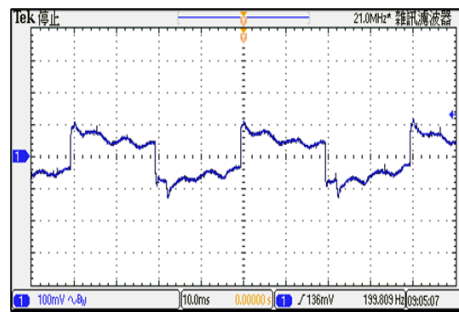

Transient Response to Dynamic Load Change
from 100% to 75% of Full Load; $V_{in}=V_{in\ nom}$

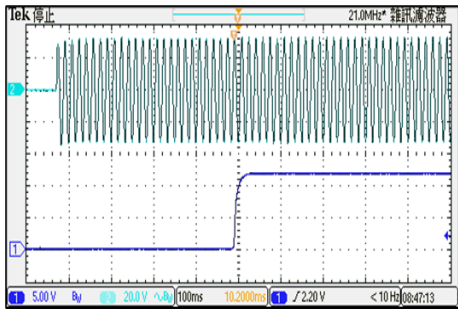

Typical Input Start-Up and Output Rise Characteristic
 $V_{in}=V_{in\ nom}$; Full Load

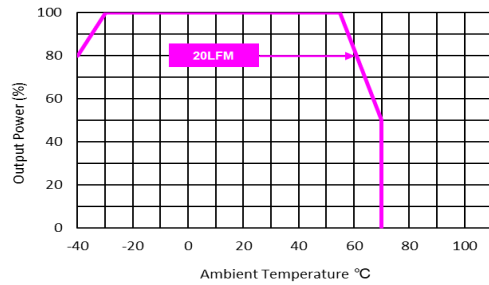

Derating Output Current Versus Ambient Temperature
 $V_{in}=V_{in\ nom}$

Characteristic Curves

All test conditions are at 25°C The figures are identical for AMF-30S15

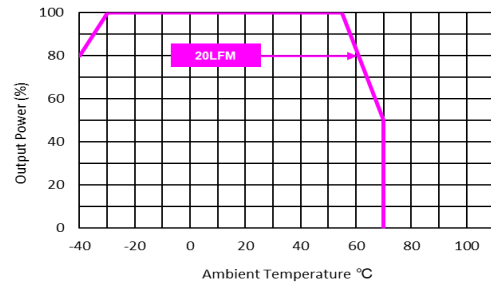
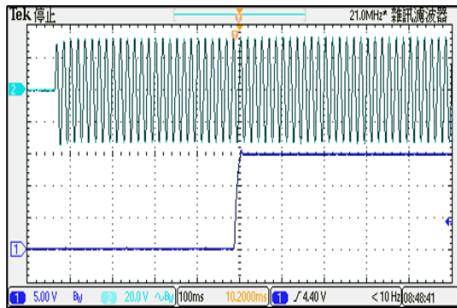
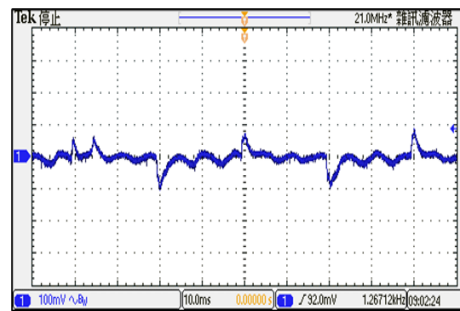
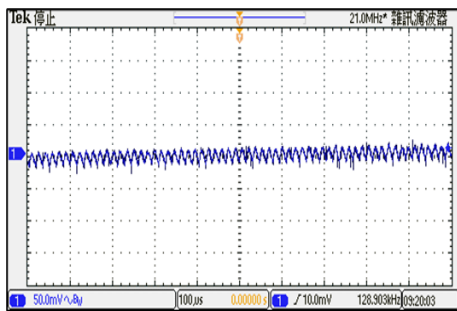
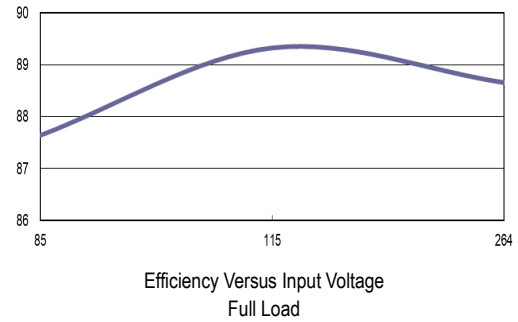
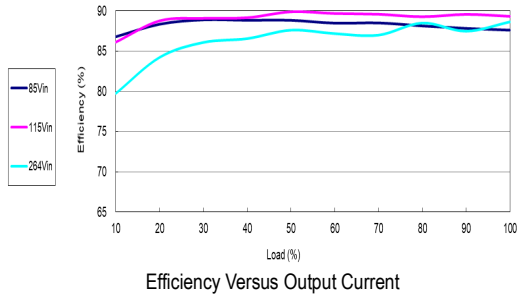

Characteristic Curves

All test conditions are at 25°C The figures are identical for AMF-30S24

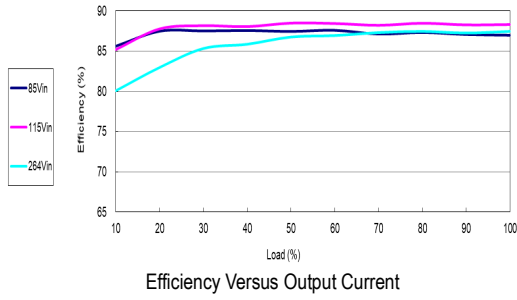

Efficiency Versus Output Current

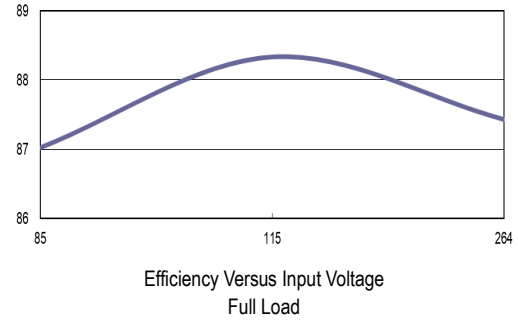

Efficiency Versus Input Voltage Full Load

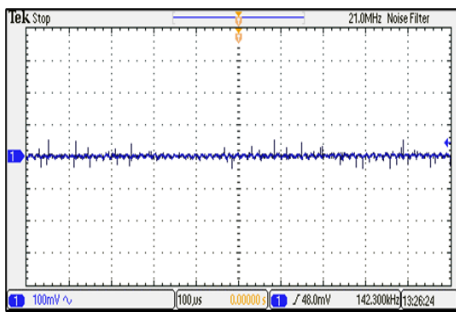

Typical Output Ripple and Noise
 $V_{in}=V_{in\ nom}$; Full Load

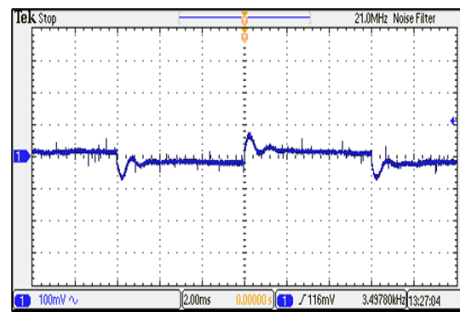

Transient Response to Dynamic Load Change
from 100% to 75% of Full Load ; $V_{in}=V_{in\ nom}$

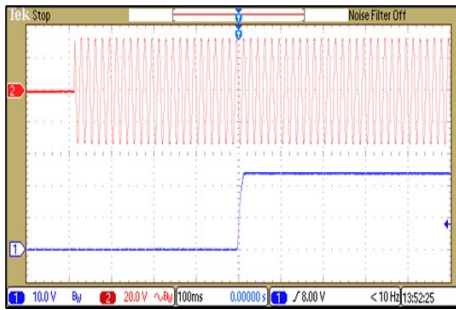

Typical Input Start-Up and Output Rise Characteristic
 $V_{in}=V_{in\ nom}$; Full Load

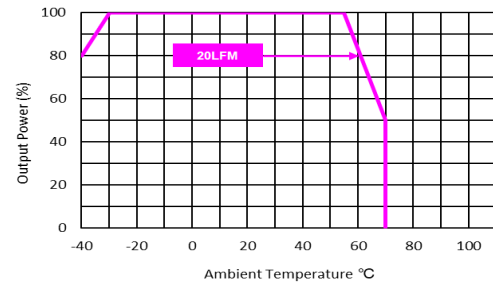

Derating Output Current Versus Ambient Temperature
 $V_{in}=V_{in\ nom}$

Characteristic Curves

All test conditions are at 25°C The figures are identical for AMF-30S48

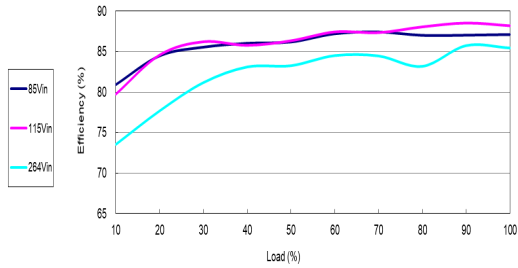

Efficiency Versus Output Current

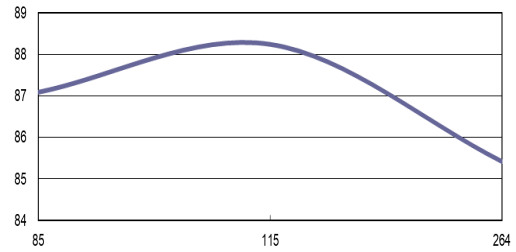

Efficiency Versus Input Voltage Full Load

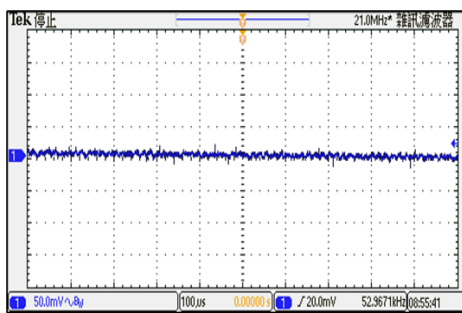

Typical Output Ripple and Noise
 $V_{in}=V_{in\ nom}$; Full Load

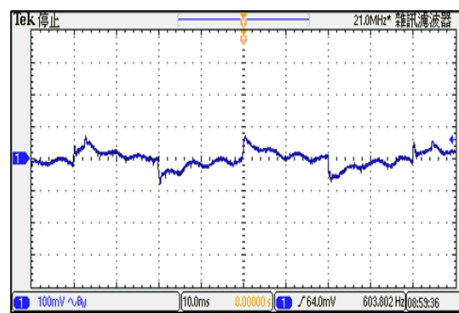

Transient Response to Dynamic Load Change
from 100% to 75% of Full Load; $V_{in}=V_{in\ nom}$

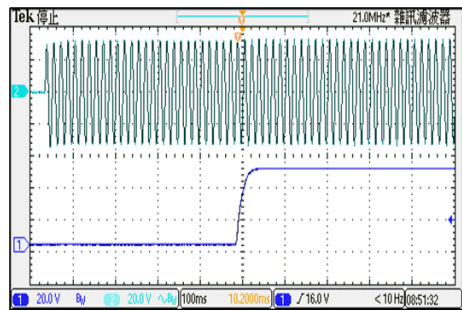

Typical Input Start-Up and Output Rise Characteristic
 $V_{in}=V_{in\ nom}$; Full Load

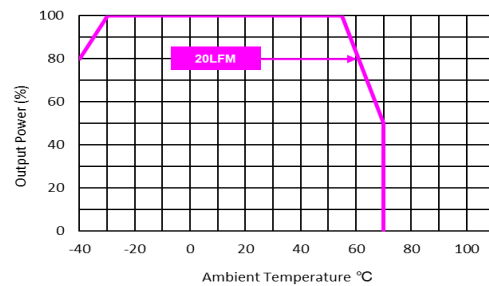

Derating Output Current Versus Ambient Temperature
 $V_{in}=V_{in\ nom}$

Package Specifications PCB Mounting

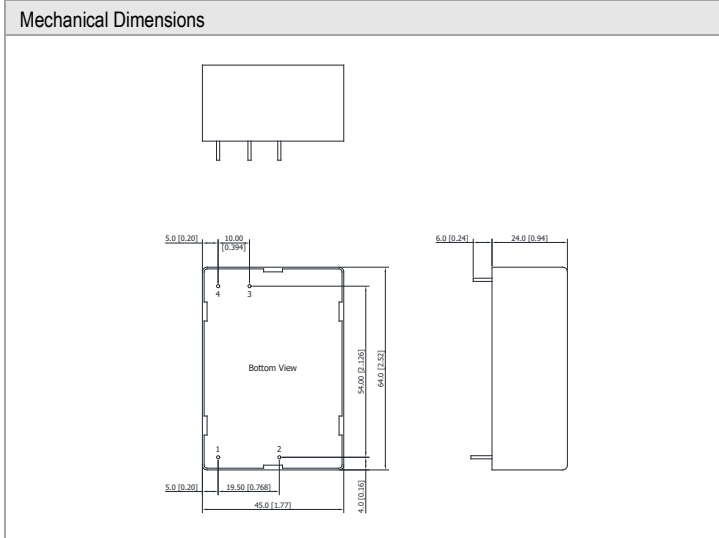

Pin Connections		
Pin	Function	Diameter mm (inches)
1	AC(L) – AC Line	∅ 1.0 [0.04]
2	AC(N) – AC Neutral	∅ 1.0 [0.04]
3	+Vout	∅ 1.0 [0.04]
4	-Vout	∅ 1.0 [0.04]

- ▶ All dimensions in mm (inches)
- ▶ Tolerance: ±0.5 (±0.02)
- ▶ Pin pitch tolerance: ±0.25 (0.01)
- ▶ Pin diameter tolerance: X.X±0.1 (X.XX±0.004)

Physical Characteristics

Case Size	: 64.0x45.0x24.0mm (2.52x1.77x0.94 inches)
Case Material	: Plastic resin (flammability to UL 94V-0 rated)
Pin Material	: Copper Alloy
Weight	: 96g

Package Specifications Chassis Mounting with screw terminal (order code suffix C)

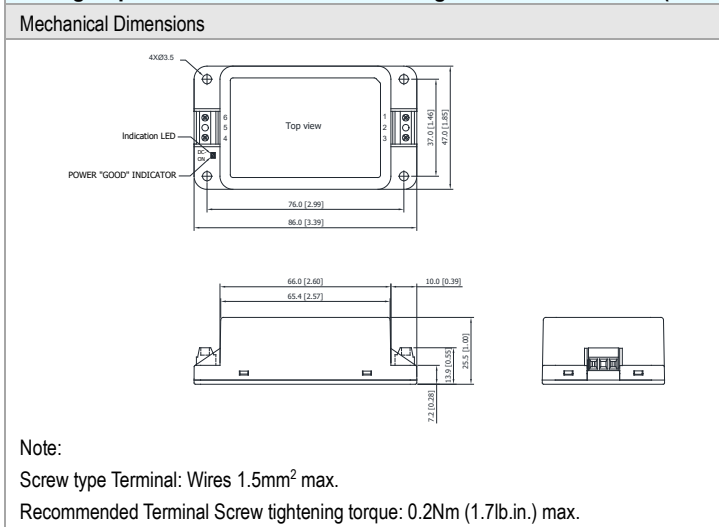

Note:
 Screw type Terminal: Wires 1.5mm² max.
 Recommended Terminal Screw tightening torque: 0.2Nm (1.7lb.in.) max.

Pin Connections	
Pin	Function
1	AC(L) – AC Line
2	No Pin
3	AC(N) – AC Neutral
4	+Vout
5	No Pin
6	-Vout

- ▶ All dimensions in mm (inches)
- ▶ Tolerance: ±0.5 (±0.02)

Physical Characteristics

Case Size	: 86.0x47.0x25.5mm (3.39x1.85x1.00 inches)
Case Material	: Plastic resin (flammability to UL 94V-0 rated)
Weight	: 116g

Package Specifications for screw terminal with DIN Rail Mounting (order code suffix AC-DIN-07)

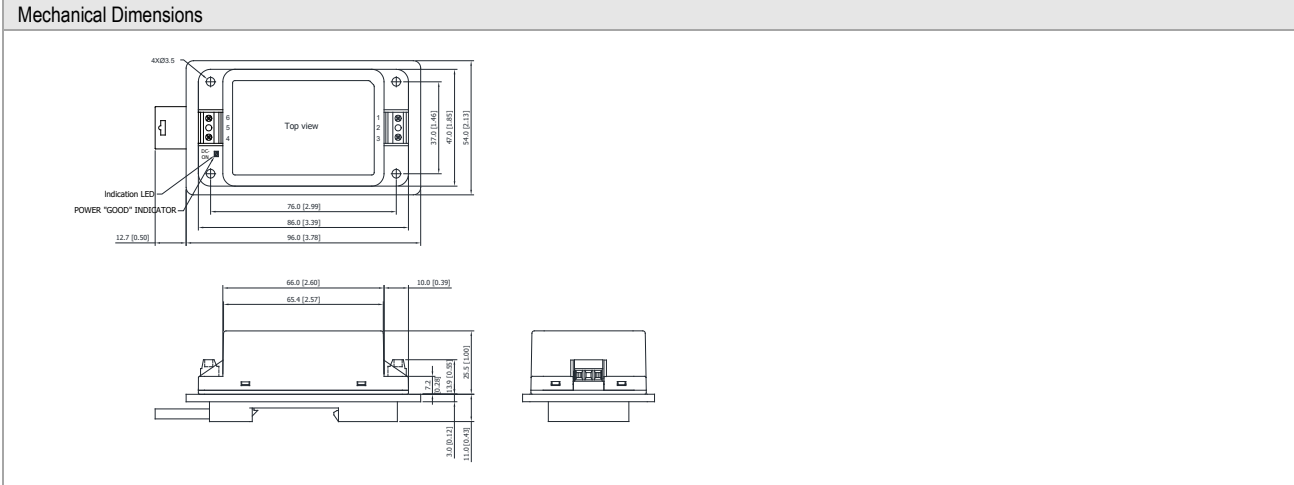

Physical Characteristics

Case Size	: 86.0x47.0x25.5mm (3.39x1.85x1.00 inches)
Case Material	: Plastic resin (flammability to UL 94V-0 rated)
Weight	: 180g

Screw terminal with DIN Rail Mounting

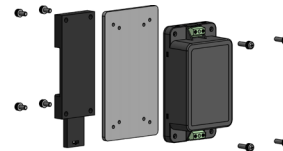
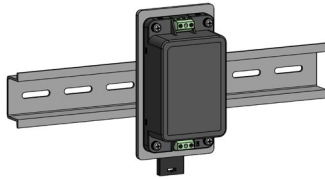

Note:

Recommended tightening torque: 0.35Nm (3.1lb.in.) max.

Package Specifications Chassis Mounting with JST connection (order code suffix CD)

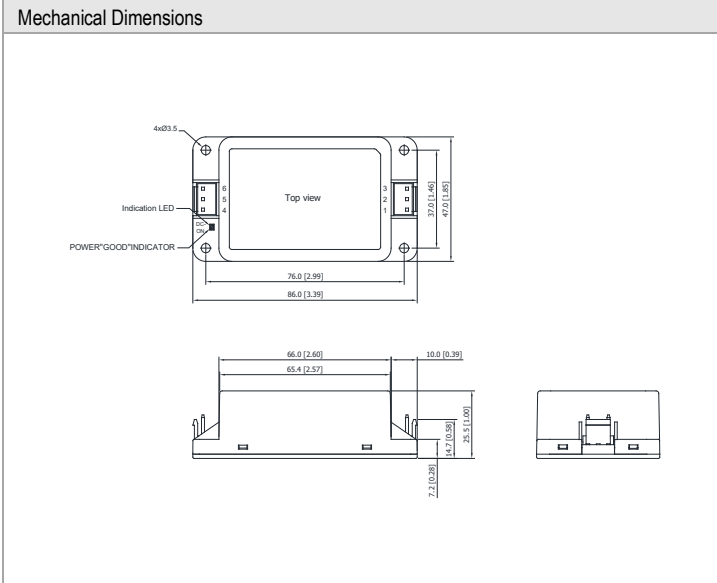

Pin Connections

Pin	Function
1	AC(N) – AC Neutral
2	No Pin
3	AC(L) – AC Line
4	No Pin
5	+Vout
6	-Vout

Input (pin 1, pin 3): JST Connector
 mates with JST crimp contacts: SVH-41T-P1.1
 terminal housing: VAR-2
 Output (pin 5, pin 6): JST Connector
 mates with JST crimp contacts: SVH-41T-P1.1
 terminal housing: VHR-3

- ▶ All dimensions in mm (inches)
- ▶ Tolerance: ± 0.5 (± 0.02)

Physical Characteristics

Case Size	: 86.0x47.0x25.5mm (3.39x1.85x1.00 inches)
Case Material	: Plastic resin (flammability to UL 94V-0 rated)
Weight	: 115g

Package Specifications for JST connection with DIN Rail Mounting (order code suffix AC-DIN-07)

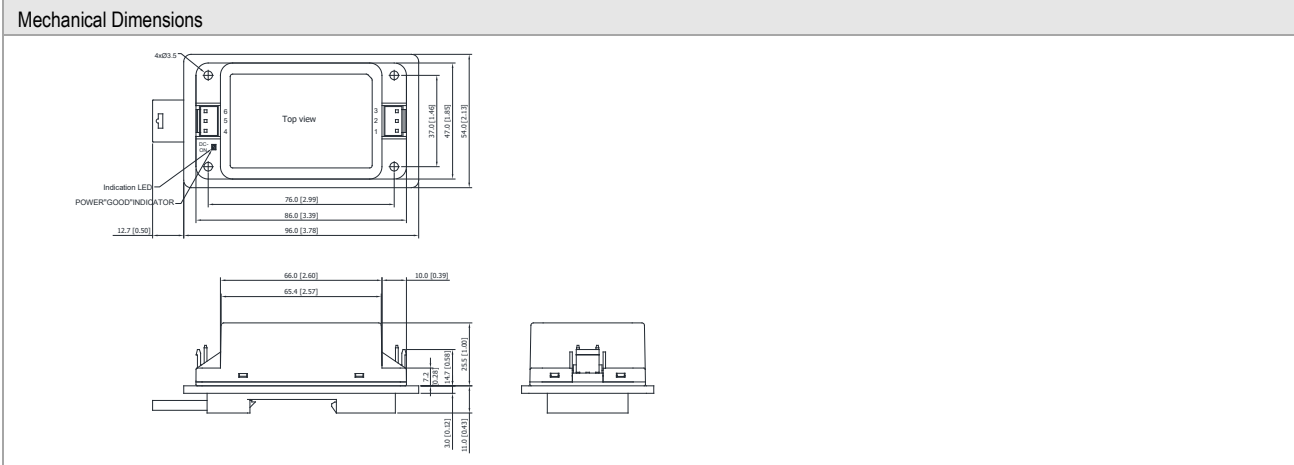

Physical Characteristics

Case Size	: 86.0x47.0x25.5mm (3.39x1.85x1.00 inches)
Case Material	: Plastic resin (flammability to UL 94V-0 rated)
Weight	: 179g

JST connection with DIN Rail Mounting

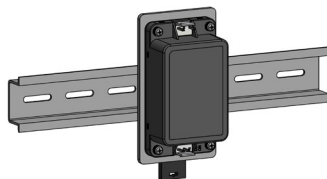

Note:
 Recommended tightening torque: 0.35Nm (3.1lb.in.) max.

Recommended Pad Layout

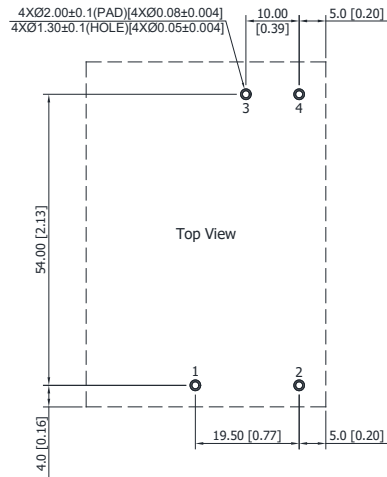

Packaging Information

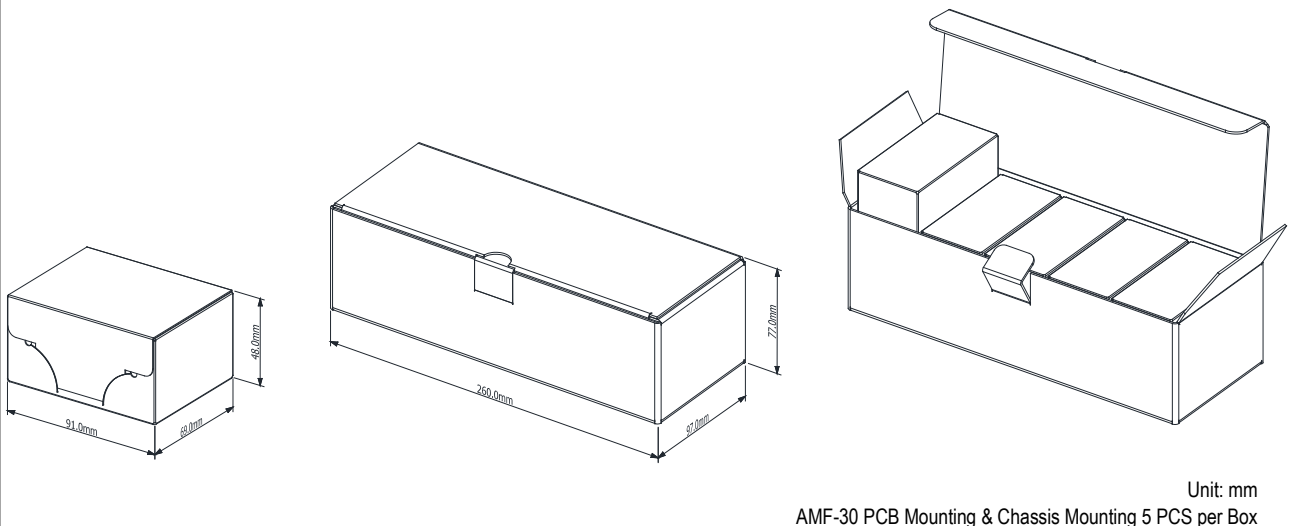

Wave Soldering Considerations

Lead free wave solder profile

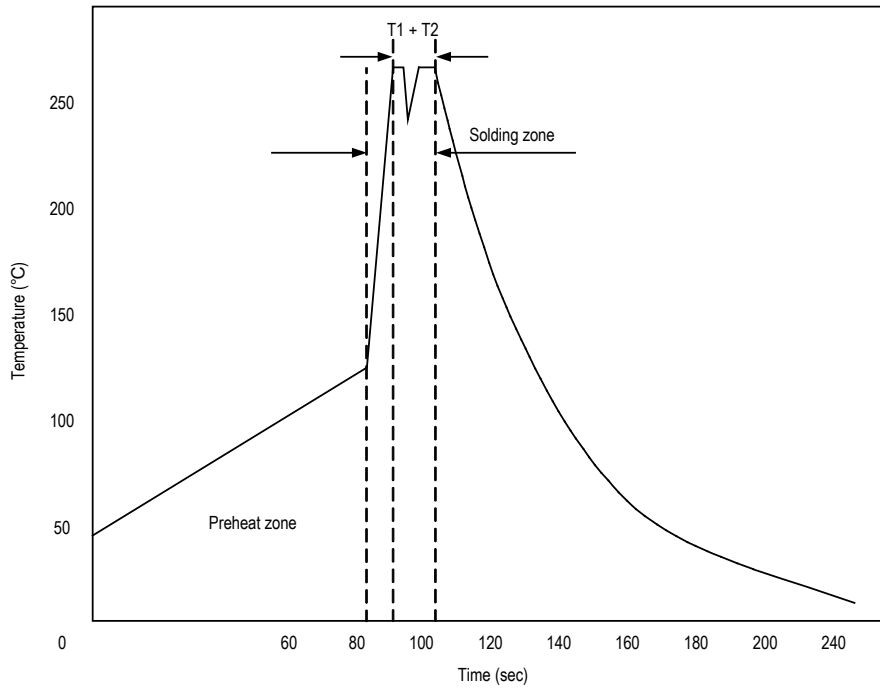

Zone	Reference Parameter
Preheat	Rise temp. speed : 3°C/sec max.
zone	Preheat temp. : 100~130°C
Actual	Peak temp. : 250~260°C
heating	Peak time(T1+T2) : 4~6 sec

Hand Welding Parameter

Reference Solder: Sn-Ag-Cu : Sn-Cu : Sn-Ag

Hand Welding: Soldering iron : Power 60W

Welding Time: 2~4 sec

Temp.: 380~400°C

Part Number Structure					
AMF	-	30	S	051	C
		Output Power 30 Watt	Output Quantity S: Single	Output Voltage 051: 5.1 VDC 12: 12 VDC 15: 15 VDC 24: 24 VDC 48: 48 VDC	Package Type N/A: PCB Mounting C: Chassis Mounting with screw terminal CD: Chassis Mounting with JST connection

MTBF and Reliability		
The MTBF of AMF-30 series of AC-DC Power Module has been calculated using MIL-HDBK 217F NOTICE2, Operating Temperature 25°C, Ground Benign.		
Model	MTBF	Unit
AMF-30S051	419,523	Hours
AMF-30S12	507,978	
AMF-30S15	531,083	
AMF-30S24	544,685	
AMF-30S48	550,680	
AMF-30S051C	414,725	
AMF-30S12C	497,131	
AMF-30S15C	519,239	
AMF-30S24C	532,233	
AMF-30S48C	537,956	
AMF-30S051CD	414,725	
AMF-30S12CD	497,131	
AMF-30S15CD	519,239	
AMF-30S24CD	532,233	
AMF-30S48CD	537,956	